

Zero Velocity – Magnetic Hall Effect Sensors – 3/8 Diameter

Fully Threaded

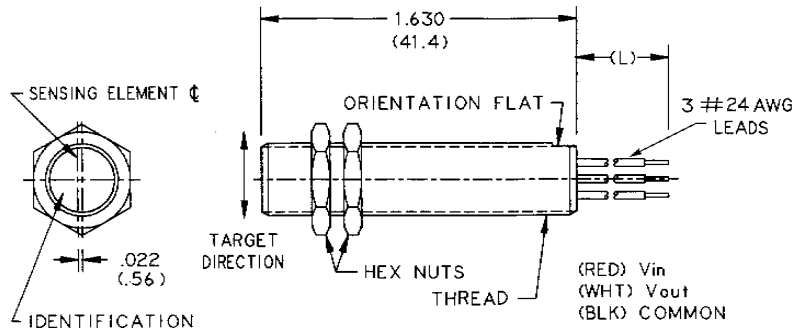

Part Num.	Thread	Cable Length (C)	Lead Length (L)	Housing Mat'l.
H1320-001	.375-32 UNEF-2A	—	12 in. (304)	Aluminum
H1320-003	.375-32 UNEF-2A	10 ft. (3.05 m)	—	Aluminum
H1320-009	.375-24 UNF-2A	—	12 in. (304)	300 St. Steel
H1320-010	.375-24 UNF-2A	10 ft. (3.05 m)	—	300 St. Steel

Net Weight: 0.7 oz. max.

Round Body

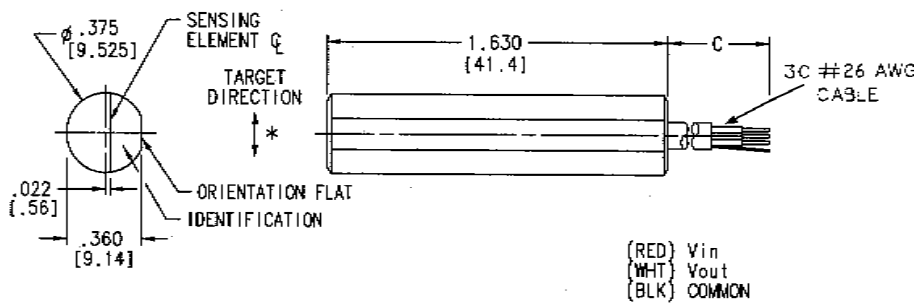

Part Number	Cable Length (C)	Lead Length (L)	Housing Mat'l.
H1320-005	—	12 in. (304)	Aluminum
H1320-006	10 ft (3.05 m)	—	Aluminum

Net Weight: 0.5 oz. max.

* Note difference in target direction with regard to flat (vs. threaded sensor).

Dimensions in inches and (mm).