

AI-TEK Instruments, LLC.

TACH•PAK® I

Instruction Manual

This manual is applicable to all Tach•Pak I models.



The logo consists of a stylized black 'A' shape with a white circle inside the top curve. Below this symbol, the text 'a.i.tek' is written in a bold, lowercase sans-serif font, and 'instruments' is written in a smaller, lowercase sans-serif font below it.

AI-TEK Instruments, LLC.

152 Knotter Drive
P.O. Box 748
Cheshire, CT USA 06410-0748
www.aitekinstruments.com



Phone: 1-800-643-0643

TM5-130 5/04
Printed in U.S.A.

Table of Contents

1.	Introduction	1
1.1.	Overview	1
1.2.	Tool List	3
1.3.	How to Use this Manual	3
1.4.	Where to Go for Help.....	4
2.	Unpacking Instructions	5
2.1.	Package Contents	5
2.2.	Unpacking.....	5
3.	Mounting and Wiring Procedures	6
3.1.	Installation and Wiring Guidelines	6
3.2.	Mounting TACH-PAK I	7
3.3.	Mounting the Speed Sensor	8
3.4.	Wiring Connections	9
3.4.1.	Accessing the Terminal Blocks	9
3.5.	Types of Speed Sensors.....	11
3.5.1.	Connecting a Passive Sensor	11
3.5.2.	Connecting an Active Sensor	12
3.5.3.	Optional Circuits	12
3.5.4.	Connecting the AC Power Supply	13
3.5.5.	Connecting a DC Power Supply	15
3.5.6.	Dual Power Supplies	15
4.	Control Panel / Display	16
4.1.	Scientific Notation.....	16
5.	Characteristics of Operation	17
5.1.	The Constants.....	17
5.2.	Constant Descriptions	17
5.3.	Special Constant (SP)	18
5.3.1.	Display Format for Special Constant (SP)	18
5.3.2.	Lowest Measured Frequency (time-out)	18
5.4.	Calibrate Frequency (CF)	19
5.4.1.	Display Format for Calibrate Frequency	19
5.5.	Setpoint Classifications	20
5.5.1.	Failsafe Setpoint	20
5.5.2.	Non-failsafe Setpoint	20
5.6.	Setpoint Categories	20
5.6.1.	Overspeed setpoint	20
5.6.2.	Underspeed setpoint	20
5.6.3.	Illustrations of setpoint types	21

5.7.	Setpoint types	22
5.7.1.	Display Format for Setpoint Frequency (S1 and S2)	22
5.7.2.	EA (Energize Above setpoint)	22
5.7.3.	Eb (Energize below setpoint)	23
5.7.4.	dA (de-energize Above setpoint)	23
5.7.5.	db (de-energize below setpoint)	23
5.8.	Hysteresis	24
5.8.1.	Display Format for Hysteresis and Type Constants (H1 and H2)	24
5.8.2.	Hysteresis bias	24
5.8.3.	Hysteresis magnitude	24
5.8.4.	Hysteresis types	24
5.9.	Frequency domain hysteresis (h)	25
5.9.1.	Example: Frequency domain hysteresis	25
5.10.	Time domain hysteresis (H)	25
5.10.1.	Example: Time domain hysteresis	26
5.11.	Delayed Trip or Latching Relay (L)	26
5.11.1.	Delayed trip	26
5.11.2.	Latching relay	26
5.11.3.	Example: Delayed trip	27
5.11.4.	Example: Latching relay	27
6.	Entering the Constants	28
7.	Reference	30
7.1.	Specifications	30
7.1.1.	Power Supply	30
7.1.2.	Signal Input	30
7.1.3.	Outputs	31
7.1.4.	Environmental	31
7.2.	Glossary	33
7.3.	Target Variable Conversions	35
	Warranty	36
	Index	37
	Recorded Stored Constants	39

I. Introduction

TACH-PAK I is a single-input industrial tachometer that measures the rate of events. Using various sensors, TACH-PAK I can measure events as simple as the speed of a rotating shaft, the rate at which paper passes through a press, or as diverse as the rate at which liquid flows through a pump. It is essentially a programmable speed switch which uses the input frequency measurements to control two relay setpoints.

1.1 Overview

A speed sensor placed near a target, such as a rotating gear, generates a repeating electrical pulse. The rate of repetition is proportional to the rate of the event you want to measure and represents the input frequency. TACH-PAK I measures this rate in number of pulses per second (hertz). This input signal from the sensor is conditioned, analyzed by a microcomputer and routed to the relay outputs.

TACH-PAK I's microcomputer uses a scheme of data acquisition called adaptive period averaging, a unique frequency measuring method in which the number of periods averaged changes with the frequency to obtain optimal accuracy. At input frequencies of 100 Hz and above, the outputs are updated every 30 milliseconds.

TACH-PAK I provides one scaleable output of:

- Two Form C (SPDT) relay setpoints

To set up TACH-PAK I, first determine how each output should behave in your application, then enter the setup information as six "constants" through TACH-PAK I's internal control panel. (See Section 4.) The constants are stored in TACH-PAK I's electrically alterable read-only memory (EAROM). They can be viewed and altered individually in much the same way you set a digital watch.

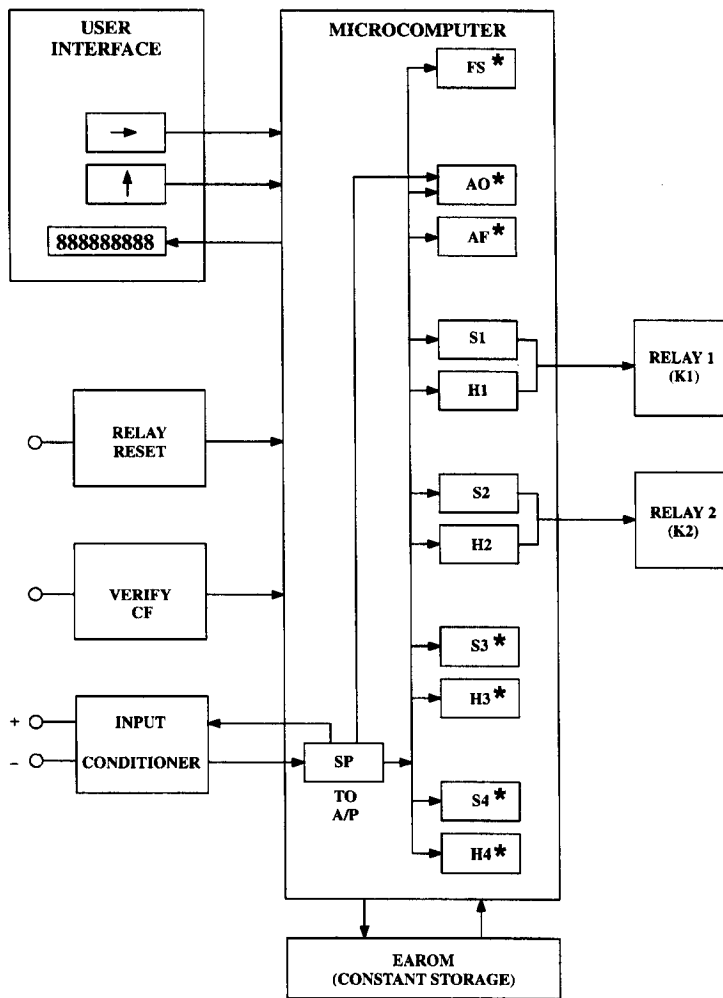

Figure 1. Operation Flow Diagram
 * Constant not used in this instrument

To put TACH-PAK I into operation, complete the following steps:

- | | |
|---|------------------------------|
| 1. Mount TACH-PAK I | See Section 3.2 |
| 2. Install and connect the appropriate output wiring. | See Section 3.4.1 |
| 3. Install and connect the speed sensor | See Sections 3.5.1 and 3.5.2 |
| 4. Install and connect the power wiring | See Section 3.5.4 or 3.5.5 |
| 5. Enter the constants into TACH-PAK I | See Section 6 |

This manual describes all five steps.



Note: By connecting temporary power wiring, TACH-PAK I can be powered up and programmed prior to mounting it on the application.

1.2 Tool List

You will need the following tools to perform the procedures described in this manual:

#1 or #2 Phillips screwdriver

#4 Phillips screwdriver

#2 straight blade screwdriver

1.3 How to Use this Manual

This manual contains the following sections:

Chapter 1 - Introduction contains a brief description of TACH-PAK I.

Chapter 2 - Unpacking Instructions describes the package contents and proper removal of TACH-PAK I.

Chapter 3 - Mounting and Wiring Procedures contains instructions for mounting the speed sensor and making the electrical connections.

Chapter 4 - Control Panel/Display describes the internal control panel and display, scientific notation, the constants, the function of each constant, and how to determine its appropriate value. Examples are provided.

Chapter 5 - Characteristics of Operation describes setpoints, hysteresis and how they are used by the constants to control the two relays.

Chapter 6 - Entering the Constants gives procedures for how to enter and store the constants.

Chapter 7 - Reference contains specifications, a glossary, and other technical information.

The Appendices contain an index and other customer information.

This manual uses the following conventions:



Note: provides an explanation or amplification.



Caution: advises you risk damaging your equipment if you do not heed instructions.



Danger: advises you risk danger to personal health if you do not follow instructions carefully.

1.4 Where to Go for Help

For technical support and programming assistance on this product, please contact your local distributor. To locate the distributor closest to you, please call:

1-800-643-0643

2. Unpacking Instructions

To ensure safe transit every TACH-PAK I is thoroughly tested and carefully packed before leaving the plant. Responsibility for its safe delivery was assumed by the carrier upon acceptance of the shipment. Claims for loss or damage sustained in transit must be made to the carrier.

2.1 Package Contents

TACH-PAK I is shipped in a single carton that contains:

- one TACH-PAK I
- one instruction manual



Note: Electrical and mounting hardware are not supplied.

2.2 Unpacking



CAUTION: TACH-PAK I is a precision instrument. Although it is designed to withstand the rigors of industrial use, excessive physical shock or vibration can damage it. Handle it carefully. Do not drop or subject it to physical extremes exceeding those specified in Section 7.1.4.

1. Place the carton on a level surface in a well-lighted area and open the top.
2. Carefully lift out TACH-PAK I and the packing material.
3. Remove the packing material.
4. Remove the instruction manual from the carton.
5. Inspect your TACH-PAK I for concealed damage.

3. Mounting and Wiring Procedures

3.1 Installation and Wiring Guidelines

Adhere to these guidelines when installing your instrument:

1. Locate TACH-PAK I away from sources of water, humidity, heat, and dust; or provide a suitable enclosure to protect it from these elements.
2. Locate TACH-PAK I away from sources of electrical noise such as, but not limited to: SCRs, triacs, buzzers, horns, motors, welding equipment, contactors, heavy current relays, and other electrical noise generating equipment.
3. Use a metal enclosure to protect TACH-PAK I from radiated electrical noise or other magnetic influences. If TACH-PAK I is removed from its original enclosure, it should be installed only in panels or cabinets with other low level electronic devices.
4. Separate low voltage signal and control wiring from switching and power wiring. Plan cabinet and panel wiring so that the power and relay wiring are dressed to one side and low level signals dressed to the other side. Plan wiring to maintain separation at entry to and egress from the enclosure.
5. Signal and control wiring should be at a minimum run in twisted pairs. Lines for magnetic pick-ups, pulse type outputs and other frequency devices should be run in separate shielded cables.
6. Try not to use commutators or slip rings to transmit low level signals. Should this be absolutely necessary, ensure that the point of contact is maintained and clean at all times. Refer questions about this type of application to your local distributor.
7. Connect the shields of shielded cables so that no current flows in the shield by first connecting all of the shields in series then to the shield terminal on TB2-9. Do not ground the shield at any point other than the instrument (if it's equipped with a non-metallic enclosure). If equipped with a metal enclosure, connect the enclosure to an earth ground.
8. Provide a power line that is free of noise and power interruption. Normally this will be a bus for use by low power electronic devices. In some cases this may require constant voltage, isolation, or noise filters.
9. DC power supplies sourcing the tachometer should operate within the limits provided in the instrument's specifications. Applications involving battery chargers should be avoided unless isolation can be provided between the charger system and TACH-PAK I.

3.2 Mounting TACH-PAK 1

Locate the TACH-PAK I enclosure to allow for proper clearances as shown in the figure below.

Drill four holes in the panel on which the TACH-PAK I is to be mounted using the figure for your model of TACH-PAK I below as a guide.

NEMA-1

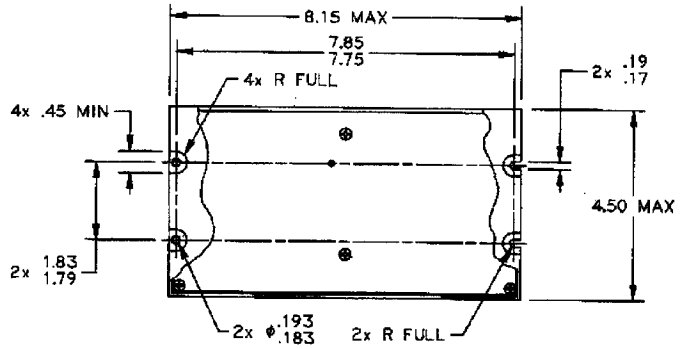
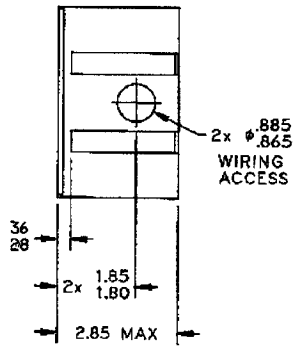

NEMA-7, -9

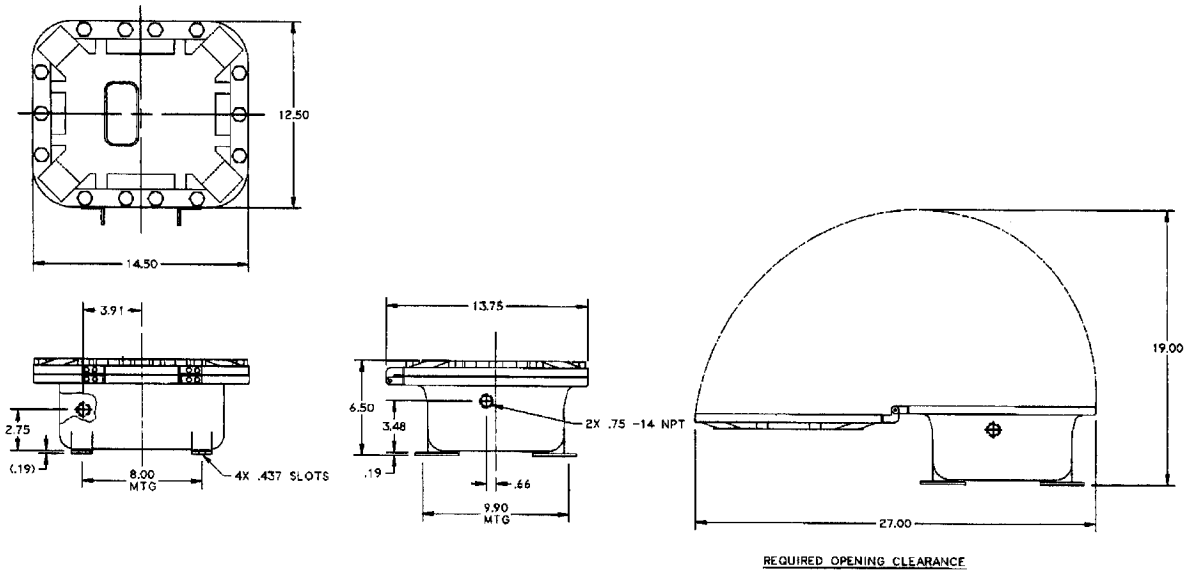

NEMA-4X

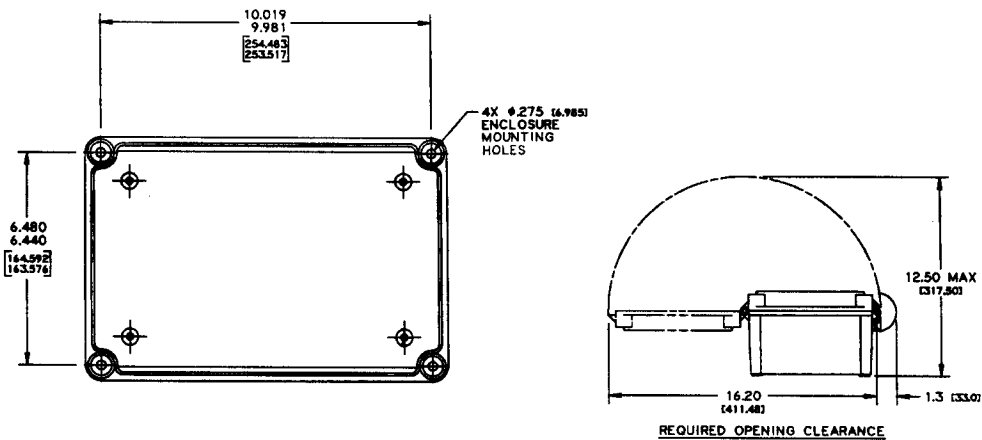

Figure 2. TACH-PAK I Dimensions and mounting hole pattern

3.3 Mounting the Speed Sensor

The sensor should be secured in a rigid mount. Normal machine vibration should not affect the accuracy of the display reading. However, relative motion between the sensor and the target can introduce false pulses and lead to incorrect readings.

Complete the following steps to mount the sensor:

1. Place the speed sensor into the mounting. Do not secure it at this time.
2. If it is an active sensor, proper orientation is required. The orientation flat or notch on the housing must be parallel with the gear teeth or target irregularity.

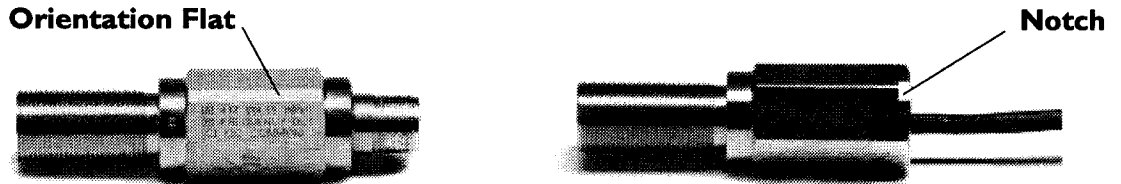

Figure 3. Active Sensor Mounting

3. When using an AI-Tek speed sensor, use a feeler gauge to set the clearance between the sensor and the gear according to the sensor specifications.

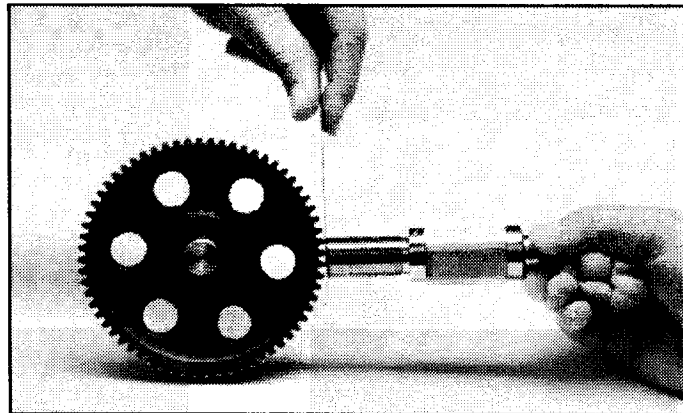

Figure 4. Setting Gap with Feeler Gauge

4. Lock the sensor securely in position with the jamb nut(s).



CAUTION: Do not overtighten the jamb nut(s).

5. Rotate the target one complete turn to ensure that the target never contacts the sensor.



CAUTION: At no time in its revolution should the target touch the sensor or damage to the sensor will occur.

3.4 Wiring Connections

Electrical connections are made to two terminal blocks inside the TACH-PAK I — terminal block 1 (TB1) and terminal block 2 (TB2). TB1 is used for AC power connections and output relay wiring. TB2 is used for DC power and sensor connections, and reset and calibrate functions.

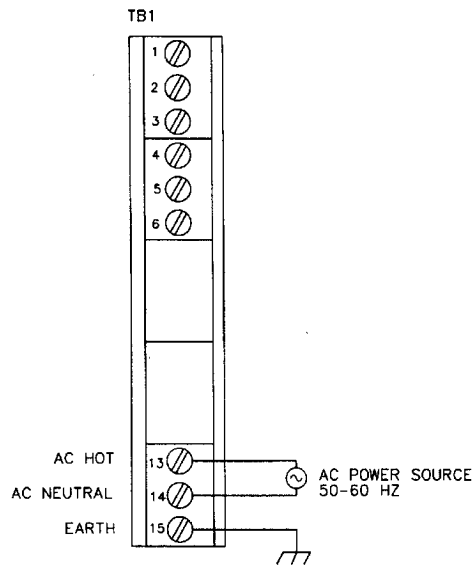

Figure 5. AC Wiring Connection

3.4.1 Accessing the Terminal Blocks

1. To access terminal block 2 (TB2), use a No. 1 or No. 2 Phillips head screw driver to remove the three screws on the top of the primary cover and lift it off.



DANGER: Before removing the subcover over the power supply, make sure TACH-PAK I is not connected to a voltage source. Line voltages are accessible when the subcover is removed.

2. To access terminal block 1 (TB1), remove the two screws on the top of the protective subcover over the power supply area and lift it off.

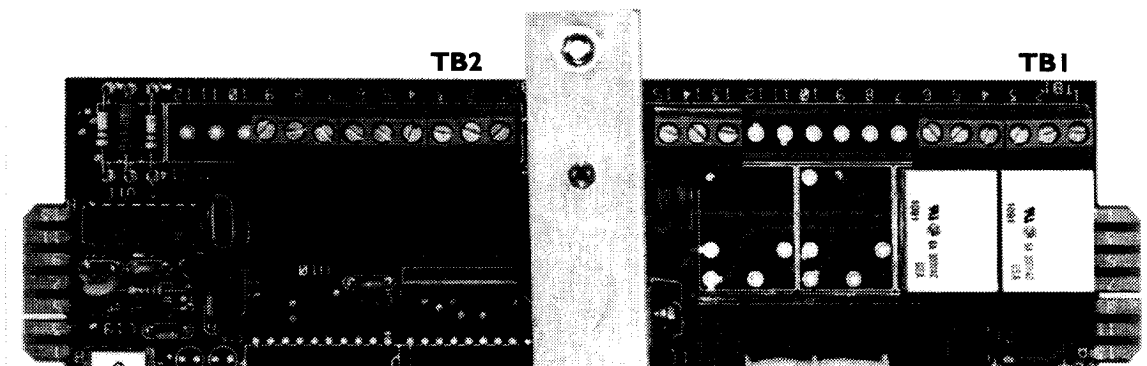

Figure 6. Terminal Blocks

The terminal block assignments are shown below.

Terminal Block Assignments			
Terminal Block 2 (TB2)		Terminal Block 1 (TB1)	
Terminal	Use	Terminal	Use
1	+24 VDC In	1	K1 N.C.
2	DC Common (power in)	2	K1 Com.
3	Calibrate/Verify	3	K1 N.O.
4	DC Common (power out)	4	K2 N.C.
5	+12 VDC Out	5	K2 Com
6	Relay reset	6	K2 N.O.
7	Signal +		
8	Signal -		
9	Shield		
		13	AC Power Hot
		14	AC Power Neutral
		15	Earth



NOTE

NOTE: Relays shown in de-energized state.



CAUTION

CAUTION: Signal leads between the sensor and TACH-PAK I should be shielded twisted pair with insulation over the shielding. This will provide effective noise shielding and is recommended for all sensor, analog output, and meter output cables. Nevertheless, do not run signal leads near noise sources such as switches and power lines that carry large currents.

Connect shields at the instrument end only. Trim the shield at the sensor end and insulate it to prevent any electrical contact with the conduit or other grounds.

3.5 Types of Speed Sensors

TACH-PAK I is designed to operate with standard AI-Tek sensors. For applications using irregular discontinuities as targets consult AI-Tek Product Catalog (#13000) or your local distributor.

The type of speed sensor used with TACH-PAK I depends on the speed of the application being monitored. Passive (non-powered) speed sensors that produce a signal in the form of an analog sine wave can be used with TACH-PAK I in most applications. Low-speed applications require active (powered) zero-velocity speed sensors that produce a signal in the form of a digital square wave. You will have to tell TACH-PAK I what type of signal it will be receiving as described in Sections 3.5.1 and 3.5.2.

If you are using another manufacturer's speed sensor, follow their recommended installation procedures.

3.5.1 Connecting a Passive Sensor

These connections are for a passive sensor producing a zero-crossing analog sine wave.

Connect the sensor as shown in the diagram below.

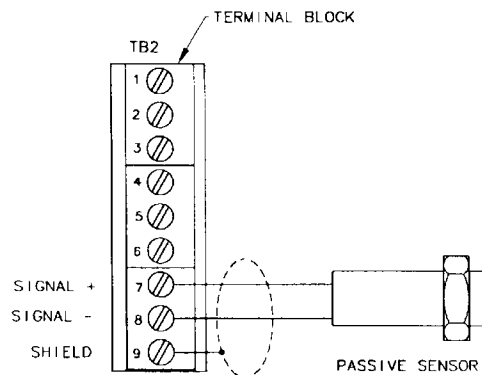

Figure 7. Passive Sensor Connection



Note: Be sure to enter a "P" for passive in the special constant (SP) when you enter the constants. (See Section 5.3.1.)

3.5.2 Connecting an Active Sensor

These connections are for an active sensor producing a ground-referenced digital square wave. Other active or TTL sensors should be connected the same way.

Connect the sensor as shown in the diagram below.

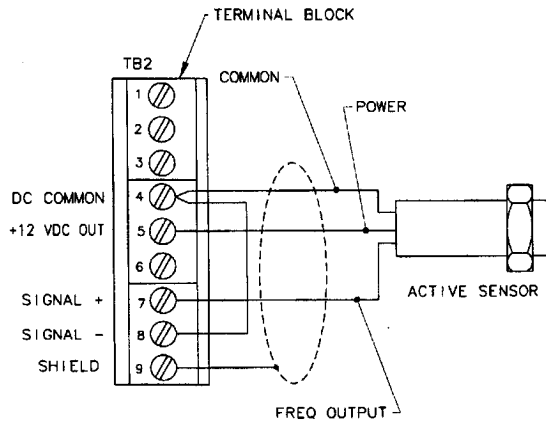

Figure 8. Active Sensor Connection



Note: Be sure to enter an "A" for active in the special constant (SP) when you enter the constants. (See Section 5.3.1.)

3.5.3 Optional Circuits

You can set up optional verification and relay reset circuits at this time according to the wiring diagrams below.

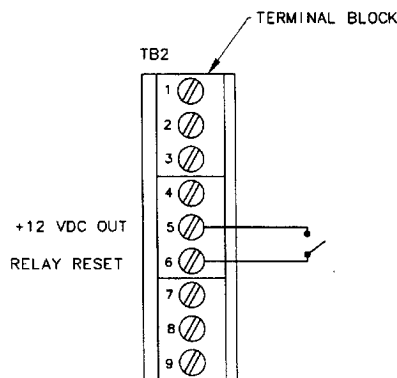

Figure 9. Relay Reset

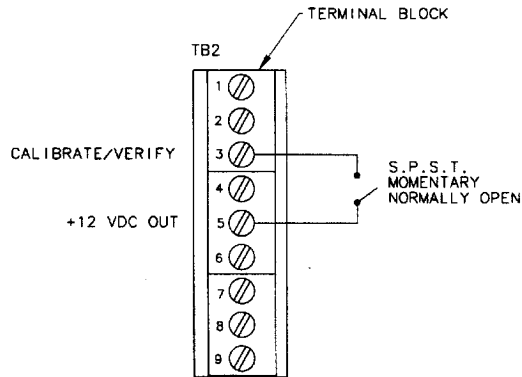

Figure 10. Calibrate / Verify Connection

3.5.4 Connecting the AC Power Supply



CAUTION: Do not exceed the maximum supply voltage to TACH-PAK I as specified in Section 7.1.1.



DANGER: A shock hazard exists in the power supply area when the power is applied to the instrument. Do not touch or place objects in the power supply area when power is being applied to the TACH-PAK I. If TACH-PAK I has already been connected to a power source, disconnect it before proceeding. Proper lockout procedures should be observed.

Attach a power cord (not provided) to TBI as follows:

- | | | |
|----|--------|------------|
| I. | TBI-13 | AC hot |
| | TBI-14 | AC neutral |
| | TBI-15 | earth |

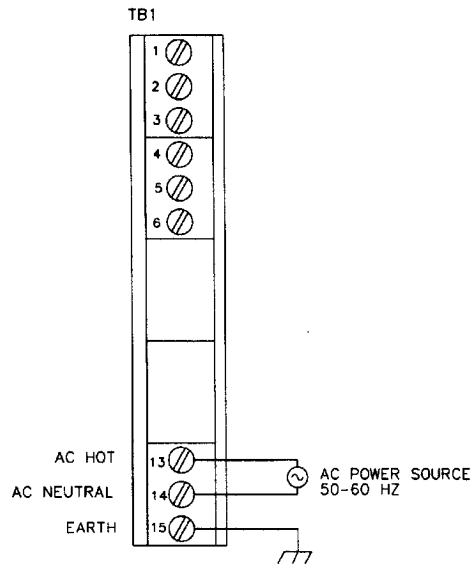

Figure 11. AC Power Connection

2. Replace the protective subcover over the power supply area to reduce shock hazard. You will not need to remove this cover again to program TACH-PAK I, only to connect the relay wiring.

3.5.5 Connecting a DC Power Supply



CAUTION: Do not exceed the maximum supply voltage to TACH-PAK I as specified in Section 7.1.1.



DANGER: A shock hazard exists in the power supply area when the power is applied to the instrument. Do not touch or place objects in the power supply area when power is being applied to the TACH-PAK I. If TACH-PAK I has already been connected to a power source, disconnect it before proceeding. Proper lockout procedures should be observed.

Attach a power cord (not provided) to TB2 as follows:

- TB2-1 +24V dc
- TB2-2 DC common

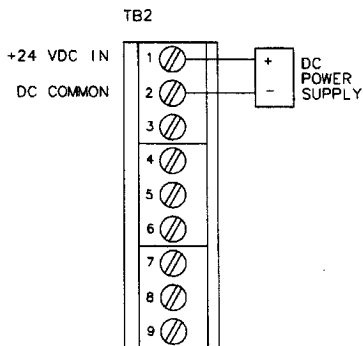

Figure 12. DC Power Connection

3.5.6 Dual Power Supplies



For applications that involve a backup or auxiliary power supply, you should make provisions to switch in the alternate power supply externally from the instrument.

In special applications it is possible to connect both an AC and a DC power source simultaneously to TACH-PAK I. However, strict attention must be paid to the system design in order to prevent damage to TACH-PAK I. Please consult your local distributor for information regarding applications utilizing dual power supplies.

4. Control Panel / Display

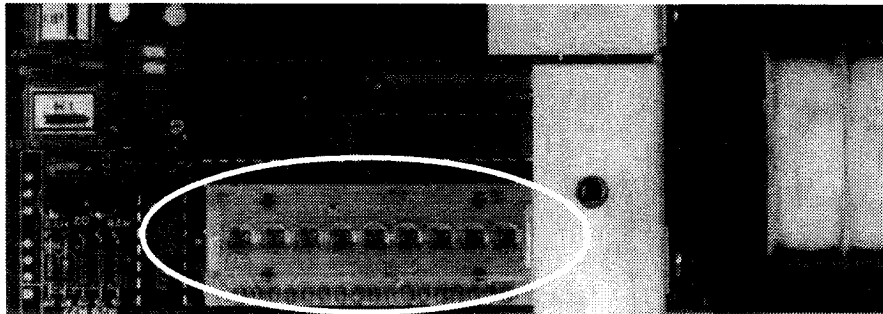
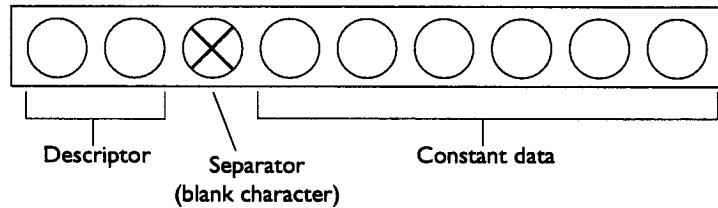
The internal control panel/display consists of two pushbuttons and a nine-character LED display used to show and modify the constants. The general layout of the display is shown below.



Modify the values of the constants using the up arrow  and right arrow  keys.

The digits appearing in the display vary according to the descriptor being displayed. The location of the cursor is shown by the blinking digit or digits.

4.1 Scientific Notation

Before entering frequency values into TACH-PAK I, convert them to scientific notation and round them to four digits. Enter only the four most significant digits and the exponent. To convert a number to scientific notation, you express it as a decimal value with one significant digit to the left of the decimal point, multiplied by a power of 10. The exponent of 10 is the number of places the decimal point has been offset to the left (positive) or right (negative). For example, in scientific notation:

$$5463 = 5.463 \times 10^3$$

$$0.00345 = 3.450 \times 10^{-3}$$

To round a number to four digits, add the necessary number of zeros to bring it up to four digits, or round off to reduce it to four digits. The following examples illustrate this:

$$65 = 6.5 \times 10 \quad 6.500 \times 10^1$$

$$54627 = 5.4627 \times 10^4 \quad 5.463 \times 10^4$$

$$0.034538 = 3.4538 \times 10^{-2} \quad 3.454 \times 10^{-2}$$

5.0 Characteristics of Operation

5.1 The Constants

The constants and their descriptors are listed below in the order they appear in the display with standard constants as set at the factory.

Constant	Descriptor	Std. Constant
Meter Full Scale Frequency	F 5 X	*
Analog Zero Scale Frequency	A 0 X	*
Analog Full Scale Frequency	A F X	*
Calibrate Frequency (verify)	C F X 3.0 0 0 0 4	
Setpoint 1 Frequency	S 1 X 5.0 0 0 0 3	
Setpoint 1 Hysteresis and Type	H 1 X E A h 1 0.0	
Setpoint 2 Frequency	S 2 X 1.0 0 0 0 4	
Setpoint 2 Hysteresis and Type	H 2 X E A h 1 0.0	
Setpoint 3 Frequency	S 3 X	*
Setpoint 3 Hysteresis and Type	H 3 X	*
Setpoint 4 Frequency	S 4 X	*
Setpoint 4 Hysteresis and Type	H 4 X	*
Special	S P X 0 X P X 1.0	

* Not used on Tach-Pak 1 even though values are shown on descriptor.

5.2 Constant Descriptions

To control the operation of TACH-PAK 1, you will determine, enter, and store values for 5 operational constants and one calibration constant in memory

This chapter describes each of the constants in detail and gives procedures and examples for determining the value of each constant. Section 6 describes how to enter and store the constants in TACH-PAK 1.



Note: Values for the constants are entered in scientific notation. If you are unfamiliar with scientific notation, see Section 4.1 for directions.

5.3 Special Constant (SP)

5.3.1 Display Format for Special Constant (SP)

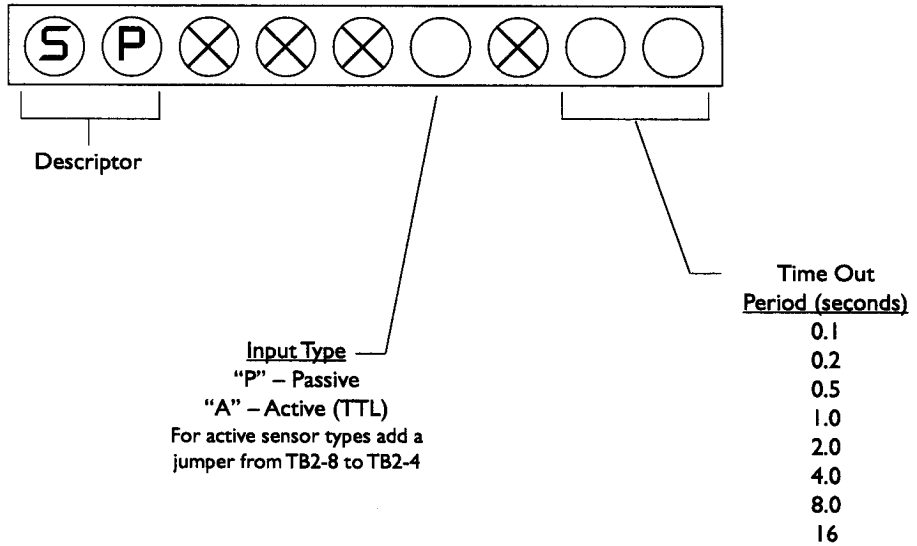

The special constant is used to set the following parameters:

- The input type (passive or active). See Sections 3.5.1 and 3.5.2.
- The lowest measured frequency (time-out period) See Section 5.3.2.

5.3.2 Lowest Measured Frequency (time-out)

This parameter sets the amount of time required to recognize that the process is stopped. You must choose one of the eight periods listed in the table below and enter the corresponding time-out period in the special constant. (See Section 6.) This is the amount of time TACH-PAK I will wait to end the data acquisition.



Note: You should not pick a time out period that is lower than is required by the application, because this period is the amount of time required to indicate zero speed.

Lowest Frequency Measured	Time-out Period
10.0000 Hz	0.1
5.0000 Hz	0.2
2.0000 Hz	0.5
1.0000 Hz	1.0
.5000 Hz	2.0
.2500 Hz	4.0
.1250 Hz	8.0
.0625 Hz	16



Note: Generally the relationship between the highest frequency measured and the lowest should be about 1000 to 1. If the highest frequency you are measuring is 5000, then you might choose 5 as the lowest measured frequency and enter 0.2 in the special constant. However, an appropriate time-out is entirely application dependent. Refer questions to your local distributor.

5.4 Calibrate Frequency (CF)

5.4.1 Display Format for Calibrate Frequency

X denotes a blank character.

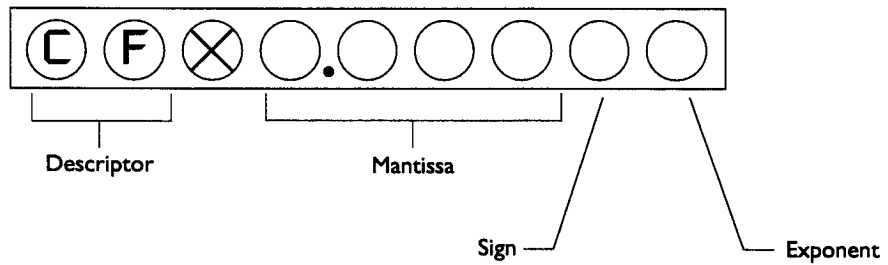

This constant is used to verify the operation of the instrument and the behavior of the outputs. When 12VDC is applied to the verify input, TACH-PAK I behaves as if the value entered in CF were the input frequency.

Use CF to:

Test the setpoints by making the verify value slightly larger than the setpoint and seeing if the relay trips.



CAUTION: When CF is active, the CF value overrides the input frequency for the duration of the applied CF signal. During this time, TACH-PAK I is not monitoring the process.

5.5 Setpoint Classifications

The TACH-PAK I has two relay setpoints (S1 and S2). A setpoint is a value of input frequency that causes a relay to change state (energize or de-energize). A setpoint value is expressed in Hertz (number of cycles per second). There are several different types of relay behavior available, and they are divided into two major classifications, Failsafe and Non-failsafe.

5.5.1 Failsafe Setpoint

Failsafe refers to a mode of operation where loss of power to TACH-PAK I will result in an alarm condition at the relay contacts. **Alarm condition** is defined as the relay state that signals a fault to auxiliary or support equipment. This type of relay behavior should be used in applications where loss of speed control cannot be tolerated or will result in a hazardous condition to personnel or monitored equipment.

5.5.2 Non-failsafe Setpoint

Non-failsafe refers to a mode of operation where loss of power to TACH-PAK I will not result in an alarm condition at the relay contacts. **Alarm condition** is defined as the relay state that signals a fault to auxiliary or support equipment. This type of relay behavior should only be used in applications where loss of speed control will not result in a hazardous condition to personnel or monitored equipment.

5.6 Setpoint Categories

Both failsafe and non-failsafe setpoints have two categories of setpoint operation, overspeed and underspeed.

5.6.1 Overspeed setpoint

Overspeed setpoints are used where control of a condition involving excess speed is required.

5.6.2 Underspeed setpoint

Underspeed setpoints are used where control of a condition involving too low a speed is required.

5.6.3 Illustrations of setpoint types

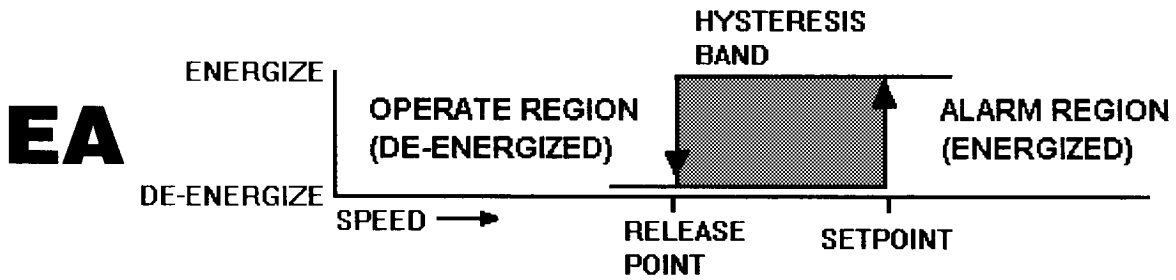

OVERSPEED, NON-FAILSAFE

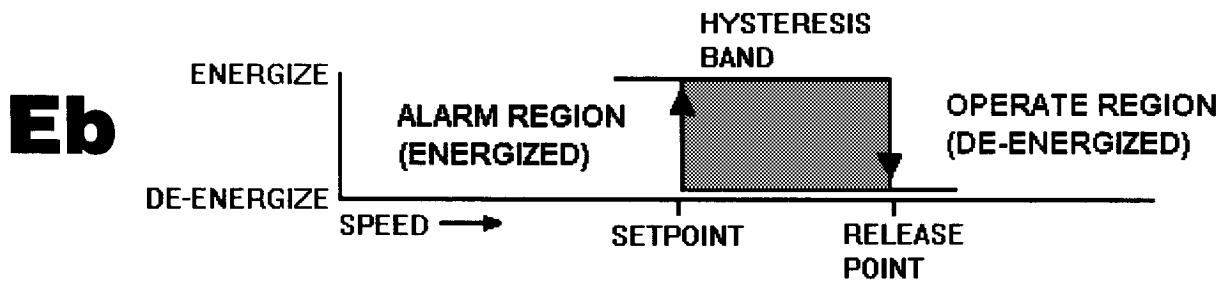

UNDERSPEED, NON-FAILSAFE

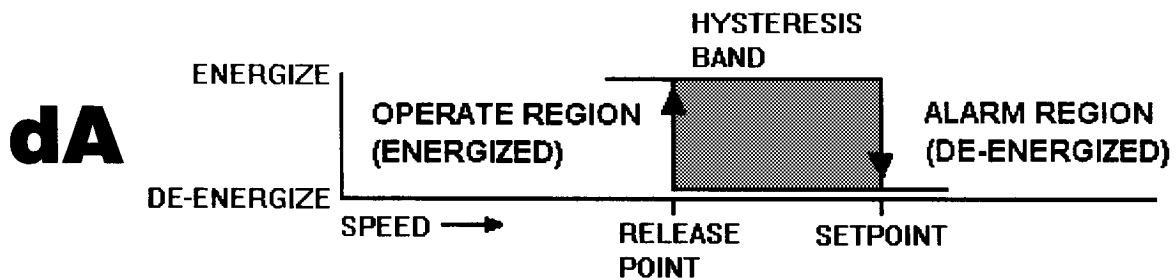

OVERSPEED, FAILSAFE

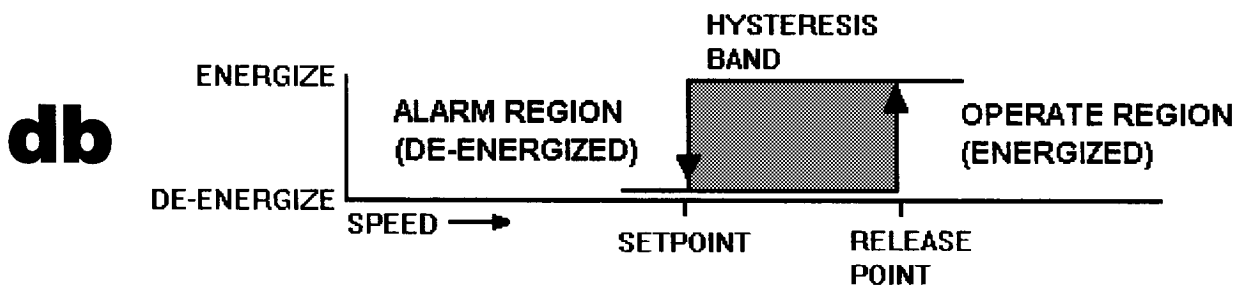

UNDERSPEED, FAILSAFE

Figure 13. Setpoint Types

5.7 Setpoint types

TACH-PAK I has two setpoint types available to each relay using the terms previously defined. They are described in the following paragraphs.

5.7.1 Display Format for Setpoint Frequency (S1 through S2)

X denotes a blank character.

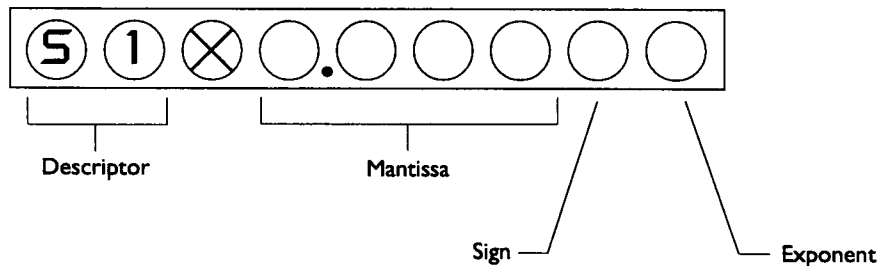

5.7.2 EA (Energize Above setpoint)

This setpoint type should be used in applications where non-failsafe control of an overspeed condition is desired. Operation of this type is as follows (Refer to the setpoint illustrations in Section 5.6.3.):

- If the monitored application is operating at a speed below the setpoint, the relay is de-energized.
- If speed increases beyond the setpoint value, the setpoint enters the alarm condition and energizes the relay.
- The relay will remain energized until the speed decreases to a value below the reset point of the hysteresis band at which point the relay is de-energized.

The reset point of a relay is determined by the hysteresis type and magnitude as configured in the hysteresis constant for that relay. For information on hysteresis refer to Section 5.8.

5.7.3 Eb (Energize below setpoint)

This setpoint type should be used in applications where non-failsafe control of an underspeed condition is desired. Operation of this type is as follows (Refer to setpoint illustrations in Section 5.6.3.):

- If operating at a speed above the setpoint, the relay is de-energized.
- If speed decreases below the setpoint value, the setpoint enters the alarm condition and energizes the relay.
- The relay will remain energized until the speed increases to a value above the reset point of the hysteresis band at which point the relay is de-energized.

The reset point of a relay is determined by the hysteresis type and magnitude as configured in the hysteresis constant for that relay. For information on hysteresis refer to Section 5.8.

5.7.4 dA (de-energize Above setpoint)

This setpoint type should be used in applications where failsafe control of an overspeed condition is desired. Operation of this type is as follows (Refer to setpoint illustrations in Section 5.6.3.):

- If operating at a speed below the setpoint, the relay is energized.
- If speed increases beyond the setpoint value, the setpoint enters the alarm condition and de-energizes the relay.
- The relay will remain de-energized until the speed decreases to a value below the reset point of the hysteresis band at which point the relay is energized.

The reset point of a relay is determined by the hysteresis type and magnitude as configured in the hysteresis constant for that relay. For information on hysteresis refer to Section 5.8.

5.7.5 db (de-energize below setpoint)

This setpoint type should be used in applications where failsafe control of an underspeed condition is desired. Operation of this type is as follows (Refer to setpoint illustrations in Section 5.6.3.):

- If operating at a speed above the setpoint, the relay is energized.
- If speed decreases below the setpoint value, the setpoint enters the alarm condition and de-energizes the relay.
- The relay will remain de-energized until the speed increases to a value above the reset point of the hysteresis band at which point the relay is energized.

The reset point of a relay is determined by the hysteresis type and magnitude as configured in the hysteresis constant for that relay. For information on hysteresis refer to Section 5.8.

5.8 Hysteresis

The function of hysteresis in setpoint relays is to provide a **dead band** that will prevent premature release of a relay in the alarm condition. AI-Tek tachometers provide a great deal of flexibility in the configuration of hysteresis behaviors or types. With each hysteresis type, the magnitude of the hysteresis band, as well as the events necessary to permit the release of a tripped setpoint, can be defined. Each setpoint has associated with it a hysteresis constant (H1 and H2). It is the configuration of this constant that determines the hysteresis behavior of each setpoint.

The hysteresis constant must be set to control the behavior of each relay setpoint being used in your application. Each hysteresis constant contains information that determines three characteristics of operation for each relay: bias, type and magnitude.

5.8.1 Display Format for Hysteresis and Type Constants (H1 and H2)

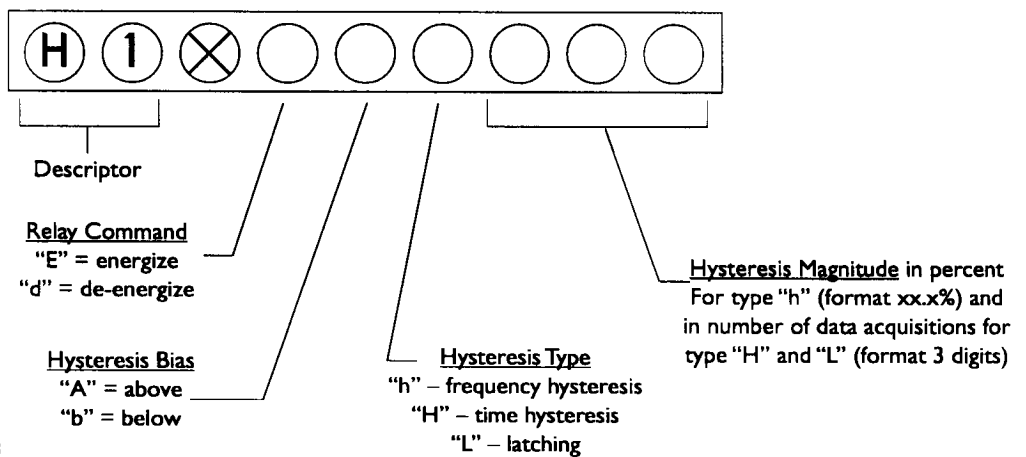

5.8.2 Hysteresis bias

The most important property of hysteresis is its bias relative to the setpoint value. It comes into effect either above or below the setpoint value. Overspeed setpoints have the hysteresis band located below the setpoint value to allow the setpoint to trip (alarm) at the prescribed value as speed increases, and to permit release of the setpoint when speed decreases to a safe level. Underspeed setpoints have the hysteresis band located above the setpoint value to allow the setpoint to trip (alarm) at the prescribed value as speed decreases, and to permit release of the setpoint when the speed increases to a safe level. Refer to the illustrations in figure 5.6.3.

5.8.3 Hysteresis magnitude

Magnitude defines the size of the dead band. The means used to describe it vary according to the type of hysteresis being applied to the setpoint.

5.8.4 Hysteresis types

TACH-PAK I has three types of hysteresis available to each relay setpoint:

- frequency domain hysteresis
- time domain hysteresis
- latching relay with delay

They are described in detail on the following pages.

5.7.3 Eb (Energize below setpoint)

This setpoint type should be used in applications where non-failsafe control of an underspeed condition is desired. Operation of this type is as follows (Refer to setpoint illustrations in Section 5.6.3.):

- If operating at a speed above the setpoint, the relay is de-energized.
- If speed decreases below the setpoint value, the setpoint enters the alarm condition and energizes the relay.
- The relay will remain energized until the speed increases to a value above the reset point of the hysteresis band at which point the relay is de-energized.

The reset point of a relay is determined by the hysteresis type and magnitude as configured in the hysteresis constant for that relay. For information on hysteresis refer to Section 5.8.

5.7.4 dA (de-energize Above setpoint)

This setpoint type should be used in applications where failsafe control of an overspeed condition is desired. Operation of this type is as follows (Refer to setpoint illustrations in Section 5.6.3.):

- If operating at a speed below the setpoint, the relay is energized.
- If speed increases beyond the setpoint value, the setpoint enters the alarm condition and de-energizes the relay.
- The relay will remain de-energized until the speed decreases to a value below the reset point of the hysteresis band at which point the relay is energized.

The reset point of a relay is determined by the hysteresis type and magnitude as configured in the hysteresis constant for that relay. For information on hysteresis refer to Section 5.8.

5.7.5 db (de-energize below setpoint)

This setpoint type should be used in applications where failsafe control of an underspeed condition is desired. Operation of this type is as follows (Refer to setpoint illustrations in Section 5.6.3.):

- If operating at a speed above the setpoint, the relay is energized.
- If speed decreases below the setpoint value, the setpoint enters the alarm condition and de-energizes the relay.
- The relay will remain de-energized until the speed increases to a value above the reset point of the hysteresis band at which point the relay is energized.

The reset point of a relay is determined by the hysteresis type and magnitude as configured in the hysteresis constant for that relay. For information on hysteresis refer to Section 5.8.

5.8 Hysteresis

The function of hysteresis in setpoint relays is to provide a **dead band** that will prevent premature release of a relay in the alarm condition. Airpax tachometers provide a great deal of flexibility in the configuration of hysteresis behaviors or types. With each hysteresis type, the magnitude of the hysteresis band, as well as the events necessary to permit the release of a tripped setpoint, can be defined. Each setpoint has associated with it a hysteresis constant (H1 and H2). It is the configuration of this constant that determines the hysteresis behavior of each setpoint.

The hysteresis constant must be set to control the behavior of each relay setpoint being used in your application. Each hysteresis constant contains information that determines three characteristics of operation for each relay: bias, type and magnitude.

5.8.1 Display Format for Hysteresis and Type Constants (H1 and H2)

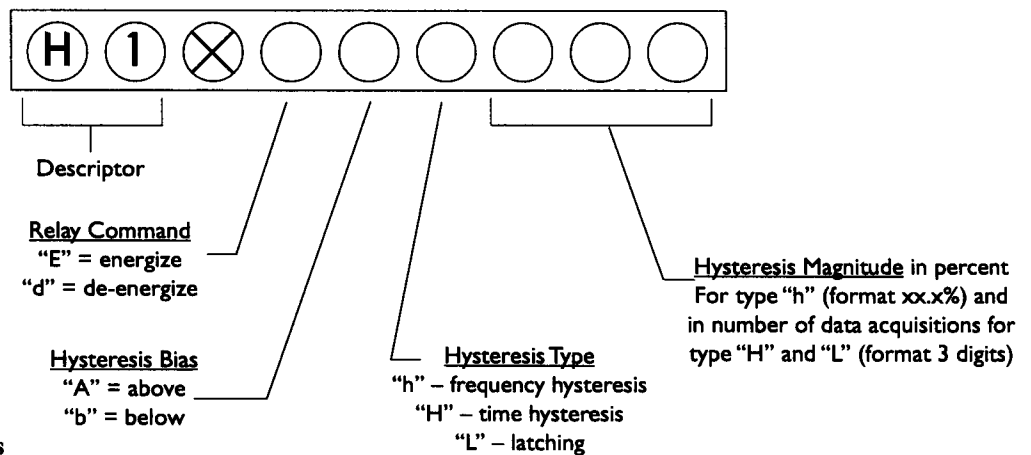

5.8.2 Hysteresis bias

The most important property of hysteresis is its bias relative to the setpoint value. It comes into effect either above or below the setpoint value. Overspeed setpoints have the hysteresis band located below the setpoint value to allow the setpoint to trip (alarm) at the prescribed value as speed increases, and to permit release of the setpoint when speed decreases to a safe level. Underspeed setpoints have the hysteresis band located above the setpoint value to allow the setpoint to trip (alarm) at the prescribed value as speed decreases, and to permit release of the setpoint when the speed increases to a safe level. Refer to the illustrations in figure 5.6.3.

5.8.3 Hysteresis magnitude

Magnitude defines the size of the dead band. The means used to describe it vary according to the type of hysteresis being applied to the setpoint.

5.8.4 Hysteresis types

TACH-PAK I has three types of hysteresis available to each relay setpoint:

- frequency domain hysteresis
- time domain hysteresis
- latching relay with delay

They are described in detail on the following pages.

5.9 Frequency domain hysteresis (h)

Frequency domain hysteresis uses a percentage of the setpoint value to calculate the reset point of a relay in the alarm condition.

5.9.1 Example: Frequency domain hysteresis

A setpoint is programmed as follows:

- setpoint configuration: EA (energize above setpoint)
- setpoint value: 1000 Hz
- hysteresis type: h
- hysteresis value: 10.0%.

The hysteresis band would be 100 Hz wide ($1000 \times .100$). The setpoint would energize the relay (alarm) if the speed was equal to or greater than 1000 Hz, and de-energize the relay (reset point) when the speed decreased to 900 Hz or less. This type of hysteresis is the most common due to its ease of use.

5.10 Time domain hysteresis (H)

Time domain hysteresis uses intervals of time (data acquisitions) in combination with the incoming frequency to calculate the reset point of a relay in the alarm condition. The magnitude of H type hysteresis is expressed as the number of consecutive data acquisitions not in violation of the setpoint.

To calculate the data acquisition time:	Example
1. Choose the setpoint frequency and delay time.	20 Hz 5 sec.
2. Multiply the input frequency by .03. If the result is not a whole number, round it to the next higher whole number.	$20 \times .03 = .6$.6 → 1
3. Multiply the result by the reciprocal of the input frequency.	$1 \times \frac{1}{20} = .05$
4. The result represents the time of one data acquisition.	.05 seconds
5. Number of data acquisitions is the delay time (sec.) divided by one data acquisition time (sec.).	$5 \div .05 = 100$
6. Time delay is specified as 0 to 999 data acquisitions.	You enter 100 as the hysteresis value portion of the constant.



Note: If the input frequency is not steady, the data acquisition time will vary in proportion to the input frequency.

5.10.1 Example: Time domain hysteresis

A setpoint is programmed as follows:

- setpoint configuration: EA (energize above setpoint)
- setpoint value: 1000 Hz
- hysteresis type: H
- hysteresis value: 010 (10 data acquisitions)

The hysteresis band would be 10 data acquisitions wide. The setpoint would energize the relay (alarm) if the speed was equal to or greater than 1000 Hz, and de-energize the relay (reset point) once the tachometer recognized 10 consecutive data acquisitions below 1000 Hz. The time interval for a data acquisition is dynamic due to the advanced scheme of adaptive period averaging employed by Airpax tachometers. For information on data acquisition times, see Section 5.13.

5.11 Delayed Trip or Latching Relay (L)

Type L hysteresis has two modes of relay operation.

1. Delayed trip (when hysteresis value is greater than 000)
2. Latching (when hysteresis value is equal to 000)

5.11.1 Delayed Trip

Type L hysteresis has the capability to delay a setpoint trip. The length of the delay is controlled by specifying the number of consecutive data acquisitions in violation of the setpoint. Once the tachometer detects that the prescribed number of consecutive data acquisitions have violated the setpoint, the relay will change state. The time interval for a data acquisition is dynamic due to the advanced scheme of adaptive period averaging employed by Airpax tachometers. For information on data acquisition times, see Section 5.13. When using the delayed trip function, the setpoint will remain in the alarm condition until the following conditions are met:

The input frequency returns to “operate” (non-alarm) region **AND** the relay reset receives a +12 VDC input. (Fig. 9)

OR

The instrument has timed-out.

5.11.2 Latching Relay

Type L hysteresis also has the capability to latch a relay in the alarm state. Once the tachometer detects that the input frequency has violated the setpoint, the relay will change state. The time interval must be set to zero to activate the latching function. When using the latching function, the setpoint will remain in the alarm condition until the following conditions have been met:

1. The input frequency must have returned to a non-alarm value.
2. The relay reset input must have received the proper input to reset the relay. On loss of power the relay will also reset.

For information on connecting the relay reset input, see Section 3.5.3.

5.11.3 Example: Delayed Trip

A setpoint is programmed as follows:

- setpoint configuration: EA (energize above setpoint)
- setpoint value: 1000 Hz
- hysteresis type: L
- hysteresis value: 010 (10 data acquisitions)

The setpoint would energize the relay (alarm) if the speed were equal to or greater than 1000 Hz for 10 consecutive data acquisitions. It would remain energized indefinitely (latched) until the following conditions are met:

The input frequency decreases below 1000 Hz **AND** the relay reset receives a +12VDC input.

OR

The instrument has timed-out.

5.11.4 Example: Latching

A setpoint is programmed as follows:

- setpoint configuration: EA (energize above setpoint)
- setpoint value: 1000 Hz
- hysteresis type: L
- hysteresis value: 000 (no data acquisitions)

The setpoint would energize the relay (alarm) if the speed were equal to or greater than 1000 Hz for zero data acquisition. The relay would remain energized indefinitely (latched) until the following two conditions are met:

1. The input frequency decreases to below 1000 Hz
2. The relay reset receives a +12VDC input.



6. Entering the Constants

To set the constants:

1. Press the up arrow key  to enter program mode. The cursor (the blinking characters) will be located on the descriptor of the first constant (CF).





CAUTION: TACH-PAK I is not monitoring the application while you are entering constants.



2. Press the right arrow key  to move the cursor to the first digit.
3. Press the up arrow key  until the desired value is displayed.



Note: Repeatedly pressing the up arrow key  will cause the display to cycle through all the available values for that digit and wrap back to the starting value.





4. Press the right arrow key  to move the cursor to the next digit.
5. Press the up arrow  to set it to the desired value.
6. Continue to set the remaining digits this way. When you are setting a sign, the display will toggle back and forth between blank for positive, and “-” for negative. Likewise, when you are setting other digits that have only two values, the display will toggle back and forth between those two values.
7. When the last digit has been set, press the right arrow key  to move the cursor back to the descriptor.

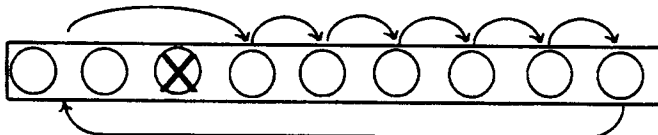

Note: When the cursor is located on the right-most character, pressing the right arrow key  causes the cursor to wrap around to the left-most character(s) as shown below. Each arrow represents one press of the right arrow key .



Press the up arrow key  to increment the display to the next descriptor.

1. Use the right arrow  and up arrow  keys to set its values in the manner just described.
2. Continue this process until all the constants have been set.
3. After the last constant has been set, press the right arrow key  to move the cursor to the descriptor on the display.
4. Press the up arrow key  until the word "store" is displayed.
5. Press the right arrow key . The display will go blank, indicating that the constants have been stored.

Note: You must complete the above step in order for the constants you have entered to take effect. If you power down TACH-PAK I before you complete this step, the constants you have entered will be lost.

6. Replace the external cover.



NOTE

Note: We suggest you keep a summary sheet (provided on page 39 of this manual) of your programmed constants so that you may refer back to these values if someone changes your original constants.

7. Reference

7.1 Specifications

7.1.1 Power Supply

Models T77130-11, T77130-41, T77130-71:

115 Vac \pm 10%, 50-60 Hz
24VDC (20-30VDC), 10 watts maximum

Models T77130-12, T77430-42, T77130-72:

230 Vac \pm 10%, 50-60 Hz
24VDC (20-30VDC), 10 watts maximum

7.1.2 Signal Input

Type:

Active or passive pickup determined by software settings (jumper required for active pickups).

AC Input (sine wave):

Input impedance = 2000 ohms
Sensitivity @ 1 kHz = 200 mVrms
Max. voltage input = 25 Vrms
CMRR = >40 db @ 1 kHz ref., to input amplifier threshold

Pulse Input (TTL-compatible):

Input impedance = 2000 ohms
Min. pulse width = 10 μ s
Logic 0 = V in < .5V
Logic 1 = V in > 1.5V
(+12VDC @ 70 mA supplied for powered sensors)

Frequency Range:

Upper limit 30 kHz
Lower limit is software selectable from .0625 Hz to 10 Hz.

7.1.3 Outputs

Relay outputs:

Two SPDT relays, rated 5 amps @ 30 VDC or 240 VAC

Frequency hysteresis selectable from 0.0% to 99.9%, or latching with remote reset

Relay logic and type selectable

Time hysteresis selectable 000 to 999 data acquisitions or latching with delay of 000 to 999 data acquisitions

Response:

50 msec updates above 100 Hz

See Auto Reset with delay for updates between 20 and 100 Hz, one cycle below 20 Hz.

7.1.4 Environmental

Temperature:

-10° to 55°C (14° to 131°F) (operating)

-40° to 80°C (-40° to 176°F) (storage)

Vibration:

Designed to meet MIL 810C, Method 514.2, Procedure VIII, Fig. 514.2-6. Curve V (15 G 10-200 Hz)

Shock:

Designed to meet MIL 810C, Method 516.2, Procedure I, Fig. 516.2-2 for ground equipment (30 G half sine)

Enclosure:

NEMA 1, 4X, 7 & 9 enclosures are available, see Section 3.2.

Humidity:

90% relative and non-condensing

Constant Storage:

Retained in EAROM and may be altered 1000 or more times

Electrical References:

Circuit common is isolated from AC power, AC ground and case. DC power, analog output, and meter output are referenced to circuit common. Passive inputs are balanced. Active pickup inputs are referenced to circuit common. Form C relay contacts are isolated.

7.2 Glossary

ACTIVE SENSOR • a powered, zero-velocity sensor that produces an output in the form of a digital square wave.

ADAPTIVE PERIOD AVERAGING • a unique frequency measuring method in which the number of periods averaged changes with the frequency to obtain optimal accuracy.

ALARM CONDITION • the relay state that signals a fault to auxiliary or support equipment.

CONSTANT • one of 6 different codes and their associated variables that control TACH-PAK 1's operation.

CURSOR • the flashing digits or characters in TACH-PAK 1's internal LED display.

DE-ENERGIZE • when a relay has no electrical power applied to its coil.

DELAY • used with latching hysteresis to postpone, by a specified number of consecutive data acquisitions that violate the setpoint, the relay's change of state into an alarm condition.

EAROM • TACH-PAK 1's Electrically Alterable Read-Only Memory where the constants are stored.

ENERGIZE • when a relay has electrical power applied to its coil.

FAILSAFE • a mode of operation where loss of power to TACH-PAK 1 will result in an alarm condition at the relay contacts.

FREQUENCY DOMAIN HYSTERESIS • a type of hysteresis which uses a percentage of the setpoint value to determine the magnitude of the dead band.

HYSTERESIS • the dead band associated with each setpoint which determines the release point of a relay in alarm. The purpose of hysteresis is to prevent relay chatter about the setpoint value and/or to ensure that the process has returned to a safe condition before releasing an alarmed setpoint. The hysteresis band can be specified by type and magnitude for each setpoint by the user.

HYSTERESIS BIAS • the location of the hysteresis relative to the setpoint, above or below.

HYSTERESIS CONSTANT • a setpoint parameter that determines the bias, magnitude, and type of hysteresis.

HYSTERESIS MAGNITUDE • the size of the dead band created by the hysteresis parameters, described either by a percentage of the setpoint value or a number of consecutive, non-alarm data acquisitions.

LATCHING • a mode of setpoint operation that requires it to be reset from the alarm condition by an external event.

NON-FAILSAFE • a mode of operation where loss of power to TACH-PAK 1 will not result in an alarm condition at the relay contacts.

OVERSPEED • a category of setpoint that is used where control of a condition involving excess speed is required.

PASSIVE SENSOR • a non-powered sensor that produces an output in the form of an analog sine wave.

RESET POINT - the point determined by the hysteresis parameters at which a relay changes state to the non-alarm condition (energize or de-energize).

SCIENTIFIC NOTATION • a means of describing a number as a mantissa (significant digits) and exponent (power of ten). TACH-PAK 1 uses only the four most-significant digits in the mantissa. For example the number 123,456 would be expressed as 1.234×10^5 .

SETPOINT • a value of input frequency that causes a relay to change state to the alarm condition (energize or de-energize).

STORE • the concluding operation when setting constants, causing them to be retained in TACH-PAK 1's EARAM.

TIME DOMAIN HYSTERESIS • a type of hysteresis which uses a specified number of data acquisitions to determine the magnitude of the dead band.

TIME-OUT • the amount of time required for TACH-PAK 1 to indicate zero speed.

TIMED-OUT • when the instrument recognizes that the input frequency has fallen below the minimum programmed frequency (as defined by the time-out constant) and sets all outputs to zero.

UNDERSPEED • a category of setpoint that is used where control of a condition involving too low a speed is required.

7.3 Target Variable Conversions

$$f = \frac{\text{RPM} \times \text{PPR}}{60} = \frac{\text{ss} \times \text{PPR}}{\pi \times D}$$

$$f = \frac{\text{UPM} \times \text{PPU}}{60} = \frac{\text{UPH} \times \text{PPU}}{3600}$$

$$\text{ss} = \frac{\text{RPM} \times \pi \times D}{60} = \frac{f \times \pi \times D}{\text{PPR}}$$

$$\text{RPM} = \frac{60 \times f}{\text{PPR}} = \frac{60 \times \text{ss}}{\pi \times D}$$

$$D = \frac{(\text{PPR} + 2)}{\text{DP}} = \frac{\text{ss} \times \text{PPR}}{f \times \pi}$$

$$\text{DP} = \frac{(\text{PPR} + 2)}{D} = \frac{25.4}{M}$$

$$M = \frac{25.4}{\text{DP}} = \frac{25.4 \times D}{(\text{PPR} + 2)}$$

$$\text{PPR} = (D \times \text{DP}) - 2$$

Definitions:

f = frequency in Hz or cycles per second (cps)

ss = surface speed in inches per second (ips)

RPM = rotary speed in revolution per minute

PPR = pulses per revolution or number of gear teeth

D = outside diameter of target (gear) in inches

π = 3.14

UPM = unit measure per minute

UPH = unit measure per hour

PPU = pulses per unit measure

DP = diametral pitch = number of teeth in 1 inch pitch diameter

M = metric module = pitch diameter in mm \div number of gear teeth

Warranty and Return Shipments Statement

The materials ordered and agreed to be furnished by Seller are warranted against defect of material or workmanship for a period of (1) year from the date of shipment, or for their rated life (whichever period ends first). Seller's obligation under the warranty is limited to repair or replacement, in Seller's option, of the defective material at Seller's factory (point of shipment) and does not extend to equipment other than of Seller's factory (point of shipment) and does not extend to equipment other than of Seller's manufacture. The warranty shall not apply to any product or part which has been subject to misuse, negligence, accident, or attempted or unauthorized repair or modification. All return shipments must be factory authorized prior to shipment, and shipment will be at buyer's expense. The only statutory warranties applicable to the materials are warranties of title and that the materials will be merchantable and, if manufactured to Buyer's specifications, that the said items conform to such specifications. UNLESS EXPRESSLY STATED ON THE FACE HEREOF, NO WARRANTY OF FITNESS FOR ANY PARTICULAR PURPOSE IS TO BE IMPLIED, NOR ARE ANY OTHER WARRANTIES WHICH EXTEND BEYOND THOSE STATED HEREIN. SELLER'S SOLE LIABILITY FOR DEFECTS OR BREACH OF WARRANTY SHALL BE REPLACEMENT OF THE MATERIALS INVOLVED, AND IN NO EVENT WILL THE SELLER BE LIABLE FOR SPECIAL OR CONSEQUENTIAL DAMAGES. FAILURE TO TEST, INSPECT AND MAKE CLAIMS FOR BREACH OF WARRANTY WITHIN REASONABLE PERIODS SHALL BE CONCLUSIVE EVIDENCE THAT THE MERCHANDISE SHIPPED IS SATISFACTORY IN ALL RESPECTS AND SUPPLIED IN ACCORDANCE WITH ORDERED SPECIFICATIONS.

LIMITATION OF LIABILITY: (a) SELLER DOES NOT UNDER ANY CIRCUMSTANCES, WHETHER AS A RESULT OF BREACH OF CONTRACT, BREACH OF WARRANTY, TORT OR OTHERWISE BE LIABLE FOR CONSEQUENTIAL, INCIDENTAL, SPECIAL OR EXEMPLARY DAMAGES, including, but not limited to, loss of profits or revenues, loss of use of or damage to any associated equipment, cost of capital, cost of substitute products, facilities or services, downtime costs, or claims of Buyer's customers. (b) SELLER'S LIABILITY ON ANY CLAIM OF ANY KIND FOR ANY LOSS OF DAMAGE ARISING OUT OF, RESULTING FROM, OR CONCERNING ANY ASPECT OF THIS AGREEMENT OR FROM THE PRODUCTS OR SERVICES FURNISHED HEREUNDER SHALL NOT EXCEED THE PRICE OF THE SPECIFIC ORDER OR SHIPMENT WHICH GIVES RISE TO THE CLAIM.

Notice Regarding Damage

These units were carefully packed in compliance with carrier regulations and thoroughly inspected before leaving our delivery plant. Responsibility for their safe delivery was assumed by the carrier upon acceptance of the shipment. Claims for loss or damage sustained in transit must, therefore, be made upon the carrier.

Concealed Loss or Damage

Concealed loss or damage means loss or damage which does not become apparent until the merchandise has been unpacked. The contents may be damaged in transit due to rough handling even though the package may not show external damage. When damage is discovered upon unpacking, make a request for inspection by the carrier's agent. Then file a claim with the carrier since such damage is the carrier's responsibility.

Visible Loss or Damage

Any external evidence of loss or damage must be noted on the freight bill or express receipt and signed by the carrier's agent. Failure to properly describe evidence of loss or damage may result in the carrier refusing to honor a claim. We definitely are not responsible for any damage incurred while merchandise is in transit. The transportation company will settle promptly all claims as they are insured and their rates cover this cost. Any correspondence in regard to loss or damage must be accompanied by a copy of the carrier's report.

Index

A

active sensor, connection 12
active sensor, orientation 8
adaptive period averaging 1, 26
Alarm condition 24
analog sine wave 11

B

battery chargers 6

C

Calibrate Frequency (CF) 19
calibration constant 17
Characteristics of Operation 17
Connecting a Passive Sensor 11
Connecting an Active Sensor 12
Connecting the Power Supply 13, 15
constant 16, 12, 17, 18, 19, 25, 32
constants, recorded stored 39
control panel 1, 16
cursor 16, 28

D

data acquisition time 25
data acquisitions 25
dead band 24
delayed trip 26
descriptor 16, 17, 28, 29
digital square wave 11
Display Digits for Frequency Constants (CF, S1, S2)
..... 19, 22
Display Digits for Hysteresis and Type Constants (H1, H2)
..... 24
Display Digits for Special Constant (SP) 18

E

EAROM 1
electrical noise generating equipment 6
Entering the Constants 28
Environmental 31
exponent 16
external reset 26

G

glossary 33

H

How to Use this Manual 3
Hysteresis (H1,H2), bias, type & magnitude 24
hysteresis constant 24

I

input frequency 1, 18, 25, 26
input signal frequency, formula 35
input type passive or active 24
Installation and Wiring Guidelines 6
internal control panel 1, 16
Introduction 1

K

keys, UP-Arrow, RT-Arrow 16

L

latching relay 27
location 8
location, mounting 7
loss or damage 5
Lowest Measured Frequency 18

M

Mounting and Wiring Procedures 6
Mounting TACH-PAK 1 7
Mounting the Speed Sensor 8

O

operational constants 17
Optional Circuits, relay reset / verify 12
Outputs 31
Overspeed setpoints 20, 21, 22
Overview 1

P

Package Contents 5
passive speed sensor 11
power cord 14, 15
power line 6
PPR 35
program mode 28
protective subcover 9, 14

R

radiated electrical noise	6
Reference	30
reset, type L relay	26
right arrow key	28
round a number	16
RPM	35

S

Scientific Notation	16, 17
setpoint classification	20
Setpoint Frequency (S1, S2)	22
shield connections	6, 10
sign, in display	28
Signal Input	30
signal leads	10
significant digit	16
Special Constant (SP)	18
Specifications	30
speed sensor	2, 3, 8, 11
speed sensor, clearance	8
standard constants	17
store, constants	29

T

target	1
TB1	9, 10, 14, 15
TB2	6, 19, 10
terminal block assignments	10
The Constants	17
timed-out	26,27,34
time-out period	22
TTL	34
TTL sensors	12
twisted pairs	6, 10
Types of Speed Sensors	11

U

Underspeed setpoints	24, 25, 27
Unpacking Instructions	5

V

verify, calibrate	23
-------------------------	----

W

Warranty	36
Wiring Connections	9

Recorded Stored Constants

<u>Descriptor</u>	<u>Section</u>	<u>Constant</u>
FS *		<input type="radio"/> F <input checked="" type="radio"/> S <input checked="" type="radio"/> <input type="radio"/> <input type="radio"/> <input type="radio"/> <input type="radio"/> <input type="radio"/> <input type="radio"/> <input type="radio"/>
AO *		<input type="radio"/> A <input checked="" type="radio"/> O <input checked="" type="radio"/> <input type="radio"/> <input type="radio"/> <input type="radio"/> <input type="radio"/> <input type="radio"/> <input type="radio"/> <input type="radio"/>
AF *		<input type="radio"/> A <input checked="" type="radio"/> F <input checked="" type="radio"/> <input type="radio"/> <input type="radio"/> <input type="radio"/> <input type="radio"/> <input type="radio"/> <input type="radio"/> <input type="radio"/>
CF	5.4.1	<input type="radio"/> C <input checked="" type="radio"/> F <input checked="" type="radio"/> <input type="radio"/> <input type="radio"/> <input type="radio"/> <input type="radio"/> <input type="radio"/> <input type="radio"/> <input type="radio"/>
S1	5.7.1	<input type="radio"/> S <input checked="" type="radio"/> 1 <input checked="" type="radio"/> <input type="radio"/> <input type="radio"/> <input type="radio"/> <input type="radio"/> <input type="radio"/> <input type="radio"/> <input type="radio"/>
H1	5.8.1	<input type="radio"/> H <input checked="" type="radio"/> 1 <input checked="" type="radio"/> <input type="radio"/> <input type="radio"/> <input type="radio"/> <input type="radio"/> <input type="radio"/> <input type="radio"/> <input type="radio"/>
S2	5.7.1	<input type="radio"/> S <input checked="" type="radio"/> 2 <input checked="" type="radio"/> <input type="radio"/> <input type="radio"/> <input type="radio"/> <input type="radio"/> <input type="radio"/> <input type="radio"/> <input type="radio"/>
H2	5.8.1	<input type="radio"/> H <input checked="" type="radio"/> 2 <input checked="" type="radio"/> <input type="radio"/> <input type="radio"/> <input type="radio"/> <input type="radio"/> <input type="radio"/> <input type="radio"/> <input type="radio"/>
S3 *		<input type="radio"/> S <input checked="" type="radio"/> 3 <input checked="" type="radio"/> <input type="radio"/> <input type="radio"/> <input type="radio"/> <input type="radio"/> <input type="radio"/> <input type="radio"/> <input type="radio"/>
H3 *		<input type="radio"/> H <input checked="" type="radio"/> 3 <input checked="" type="radio"/> <input type="radio"/> <input type="radio"/> <input type="radio"/> <input type="radio"/> <input type="radio"/> <input type="radio"/> <input type="radio"/>
S4 *		<input type="radio"/> S <input checked="" type="radio"/> 4 <input checked="" type="radio"/> <input type="radio"/> <input type="radio"/> <input type="radio"/> <input type="radio"/> <input type="radio"/> <input type="radio"/> <input type="radio"/>
H4 *		<input type="radio"/> H <input checked="" type="radio"/> 4 <input checked="" type="radio"/> <input type="radio"/> <input type="radio"/> <input type="radio"/> <input type="radio"/> <input type="radio"/> <input type="radio"/> <input type="radio"/>
SP	5.3.1	<input type="radio"/> S <input checked="" type="radio"/> P <input checked="" type="radio"/> <input type="radio"/> <input checked="" type="radio"/> <input type="radio"/> <input checked="" type="radio"/> <input type="radio"/> <input checked="" type="radio"/> <input type="radio"/>

* NOT USED