

Sensors



a.i.tek

instruments

(800) 576 - 6308

Distributed By  Inc,

Speed Sensors

AI-Tek Instruments manufactures hundreds of different designs of speed sensors. This catalog lists the standard units we developed, based on years of design experience and knowledge, to provide you readily available products to solve your sensor solution to your speed control or indication needs. Many of the hundreds of AI-Tek speed sensors we produce are designed for special applications which allows us to offer a highly versatile and flexible product line.

Designed to meet severe industrial, automotive and aerospace environments, AI-Tek speed sensors, will provide reliable, around-the-clock operation for many years under adverse conditions. Our design engineers have paid particular attention to trouble areas such as vibration, shock, extreme temperatures, wet, oily and corrosive atmospheres. Many of our speed sensors are specifically designed for high temperature, high or low speeds, various targets or for precise accuracy and timing applications. AI-Tek uses primarily the three technologies of variable reluctance, magneto-resistive and Hall effect to convert motion into an electronic signal. By selecting the best technology for a specific application we can assure years of reliable performance.

This catalog offers a variety of options readily available through our distributors. If you cannot find a catalog item to meet your specific requirements, please contact your area distributor with your specifics; there is probably an existing design which comes close to your requirements. As a world leader in producing quality speed sensors, AI-Tek Instruments will provide a superb price/performance ratio.

Passive Magnetic Sensors

Control and protection circuits have relied on variable reluctance technology for years. With few components and no moving parts, the passive magnetic speed sensors can provide a signal from the inside of an aircraft engine at temperatures approaching 425°C or from the hub of an automobile wheel at high shock and vibration. The advantages of these sensors are:

- High reliability
- Simple installation
- Long life due to no moving parts or contacts
- Self powered operation
- Wide variety of shapes and sizes
- Easy alignment
- Can be designed for almost any environment

Due to their flexibility, you will find AI-Tek variable reluctance sensors in everything from low-cost consumer products to highly-accurate automotive engine ignition systems to flight-worthy aircraft engine controls.

It is the customer's responsibility to determine whether the product is proper for customer's use and application.



Principles of Operation

The internal construction of the typical AI-Tek variable reluctance sensor is a magnet, pole piece and coil (See figure 1). A magnetic field (lines of flux) extends from the magnet, through the pole piece and coil out into the air space at the end of the sensor. The return path of the magnetic field is from the air space to the other end of the magnet. As a ferrous object approaches the tip of the pole piece, the magnetic field increases and then decreases as the object moves away from the pole piece. The snap or the rapid change in the magnetic field induces an AC voltage signal in the coil. With an ideal target and matching sensor, the induced voltage is in the shape of a sine wave.

As can be seen, the generated frequency signal is directly proportional to the number of ferrous objects passing the pole piece per unit time. The amplitude of the voltage output is proportional to the speed of the ferrous objects passing the pole piece.

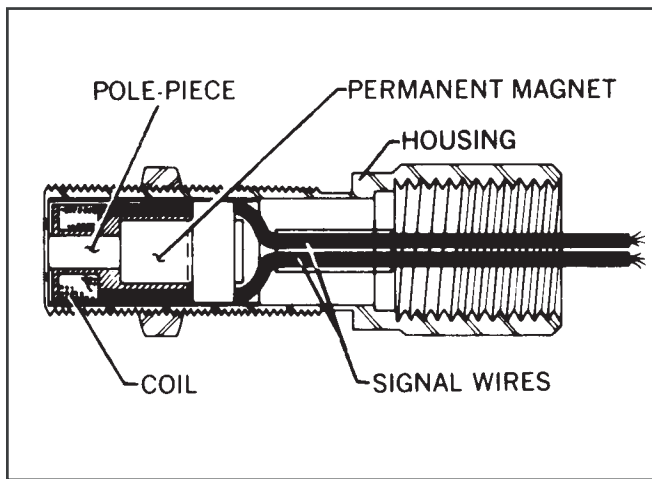

Figure 1 - Internal configuration of typical sensors.

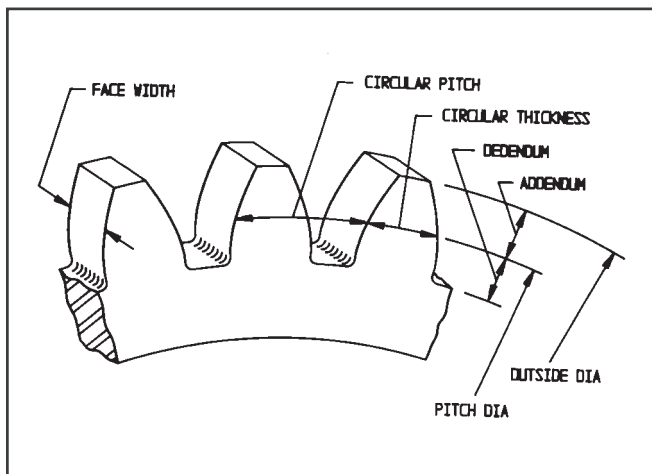

Figure 2 - Common terms used in defining gears.

Many applications of AI-Tek magnetic sensors use gears as targets. Typical sensor output wave forms with various targets are illustrated in Figure 3. Testing sensors with gears rather than other ferrous discontinuities such as sprockets, keyways, boltheads, etc. is because the output is predictable and repeatable. See Figure 2 for commonly used gear terminology.

$$\text{Diametral Pitch} = \frac{\text{No. of Teeth} + 2}{\text{Outside Dia. of Gear (in.)}}$$

The performance of a sensor can be easily defined when using a gear for a target; it also allows for estimated performance with alternate targets. AI-Tek sensors are tested with AGMA standard gears; the performance curves are included in this catalog.

AI-Tek Instruments differs from most sensor manufacturers in the presentation of performance curves and test parameters. Most existing data is specified at a surface speed of 1000 in/sec and 0.005 in. air gap; we feel that a 0.030 in. air gap and 500 in/sec. surface speed (1800 RPM motor with 5 to 6 in. dia. gear) are more realistic parameters to specify performance.

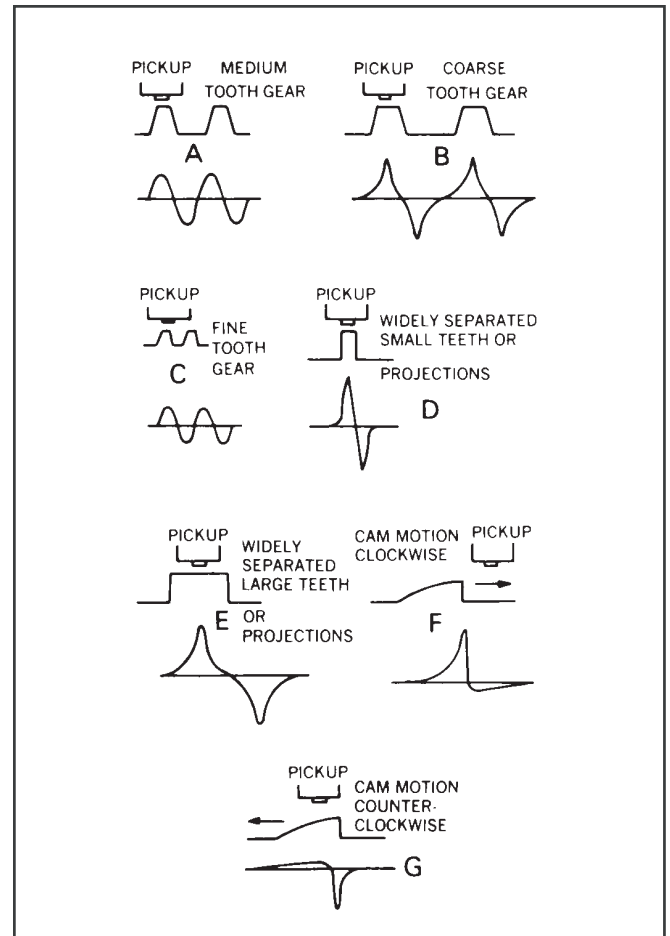

Figure 3 - Generated voltage waveforms.



Magnetic Sensor Selection

The following information is supplied for assistance in selecting the proper sensors for your particular applications. One of the fundamental questions to be answered is, "Will there be enough sensor output voltage at the lowest operating speed?"

The sensor output voltage depends on:

- *Surface Speed* - speed target passes pole piece
- *Gap* - distance between target and pole piece
- *Target Size* - geometric relationship of pole piece and target
- *Load Impedance* - connected to sensor

The surface speed of a gear depends upon its diameter and RPM. Surface speed is expressed in terms of inches per second (IPS).

$$\text{Surface Speed (IPS)} = \frac{\text{RPM} \times \text{Outside Dia. (in.)} \times \pi}{60}$$

There is an optimum pitch (or tooth size) to obtain the highest possible output from a sensor, but this is seldom necessary. Figure 4 illustrates the relationship of tooth size and spacing for optimum magnetic sensor output. Using a fine tooth gear, relative to a large pole piece diameter sensor, results in a lower generated voltage because the flux also passes into adjacent teeth, resulting in a lower total flux variation.

The relationship between pole piece diameter and gear pitch and its effect on the output of a sensor is described in Table A.

The load impedance, with relation to the internal impedance of the sensor, dictates the amount of sensor output voltage that will be seen by that load.

Magnetic sensors are designed with the lowest practical impedance consistent with providing maximum output. The load impedance should be high in relation to the impedance of the sensor to minimize the voltage drop across the coil and to deliver the maximum output to the load.

Most of the output voltages listed in this catalog are based on a load impedance of 100k ohms. To use a generality, the load impedance should be 10 times that of the sensor.

In order to assist you in selecting your sensor, AI-Tek Instruments has developed an output vs. speed curve for each sensor family. By looking at the application extremes of highest speed/lowest gap and lowest speed/highest gap, the full variation of sensor output can easily be determined. We also specify each family in two ways **Standard** - minimum output voltage at 1000 IPS, 0.005 in. gap. **Guarantee Point** - minimum output voltage at 500 IPS, 0.030 in. gap. Sensors with .187" dia. pole piece are tested with an 8 D.P. gear, 100k ohms load; .106" dia. & smaller pole piece sensors are tested with a 20 D.P. gear, 100k ohms load.

Table A: Relative Output Vs. Gear Pitch

Pole Piece Dia. (in)	Gear Pitch						
	8	12	16	20	24	32	48
.187	1.00	0.83	0.33	0.16	—	—	—
.106	1.41	1.41	1.27	1.00	0.70	0.28	0.07
.093	1.25	1.25	1.25	1.00	0.75	0.37	0.12
.062	0.95	1.07	1.00	1.00	0.92	0.90	0.36
.040	1.00	1.00	1.00	1.00	1.00	0.90	0.60

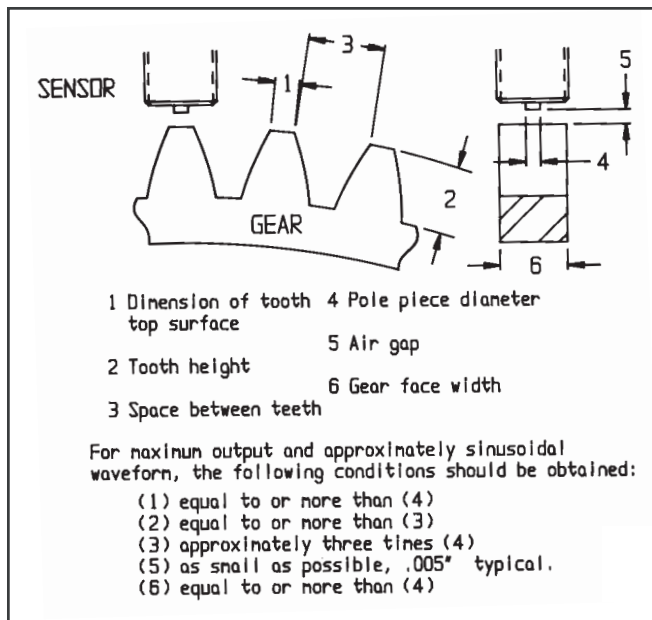

Figure 4: Sensor output as a function of gear tooth size.

Calculation of Output Voltage

Selection of the proper AI-Tek magnetic sensor may require the calculation of sensor output voltage to assure proper operation in your specific application. To assist in this area, let us consider the following typical application: Requirement is speed display with overspeed and underspeed control as well as 4-20 mA signal to a PLC. Speed range is 0-3600 RPM with low speed set point at 300 RPM, available shaft diameter for mounting a gear is 2.000 in. and a .030 in. air gap is ideal.

You have selected a Tachtrol 3, P/N T77310-11, with a 60T steel, split gear, P/N G79870-202-1901, and you are considering to use sensor P/N 70085-1010-001. The question is if the sensor has enough output voltage at 300 RPM.

We can list the following parameters:

- a. Tachtrol 3: Load impedance - 2000 ohms
Sensitivity - 200 mV rms
- b. Split gear: Outside dia. - 5.166 in.
D.P. - 12
No. of Teeth - 60
- c. Sensor: Standard output voltage - 40V (P-P) min.
Guarantee Point - 3.4V P-P min.
D.C. Resistance - 130 ohms max.
Typical inductance - 33 mH ref.

Step 1: Calculate surface speed of gear:

$$SS = \frac{RPM \times \text{Outside Dia.} \times \pi}{60} = \frac{300 \times 5.166 \times 3.14}{60}$$

$$SS = 81 \text{ IPS}$$

Step 2.: Determine Peak-to-Peak output voltage:

Referring to the performance curves of sensor P/N 70085-1010-001 the min. output voltage is approx. 0.3 V (P-P) at 81 IPS and 0.030 in. gap. It is a fact that output voltage vs. surface speed is a near linear function; therefore, another method of determining output voltage is to set up a ratio using the guarantee point:

$$\frac{3.4V \text{ (P-P)}}{500 \text{ IPS}} = \frac{E}{81} \quad E = .55V \text{ (P-P)}$$

Step 3: Correction for pitch:

For a 0.106 in. pole piece dia. and a 12 D.P. gear the correction factor from Table A is 1.41. (See pg. 25.)

$$E_c = .55 \times 1.41 = .78 \text{ V (P-P)}$$

Step 4: Converting to rms voltage:

Simply divide by 3, a method which is close enough. (If the peak-to-peak output voltage is a sine function, the divisor is 2 times the square root of 2 or 2.83).

$$E_c = .78 \div 3 = .26 \text{ V rms}$$

Step 5: Correction for load:

The .26V or 260 mV rms sensor output voltage will be divided across the impedance of the load and sensor. The load impedance is 2000 ohms resistive. The impedance of the sensor has a resistive and inductive element. At low frequencies the inductive element is very small and can therefore be disregarded, leaving the max. DC resistance of 130 ohms for consideration.

The load correction factor (f_L) can be expressed as:

$$f_L = \frac{Z(\text{load})}{Z(\text{load}) + Z(\text{sensor})} = \frac{2000}{2130} = .94$$

$$E_c = .94 \times 260 = 244 \text{ mV rms}$$

The final adjusted value is 244 mV rms.

As stated earlier, the sensitivity or threshold of the Tachtrol•3 is 200 mV rms at the stated conditions, the selection of P/N 70085-1010-001 is acceptable.

If the final value of E_c had been slightly less than 200 mV, a reduction of the air gap (from .030" to .025") would boost the output above 200 mV.

If it should be determined that the required sensor cannot be selected from the catalog models, the best procedure is to compile a list of all your requirements and contact your area distributor to assist you in the selection of the correct sensor.

Passive Speed Sensors

5/8 – 18 FAMILY

General Purpose

Ordering Part #	Thread Length (A)
70085-1010-001	1.125 (28.57)
70085-1010-003	2.625 (66.67)
70085-1010-018	3.625 (92.07)
70085-1010-118	5.000 (127.00)

(Select cable from group "A", see index)

Performance Curves

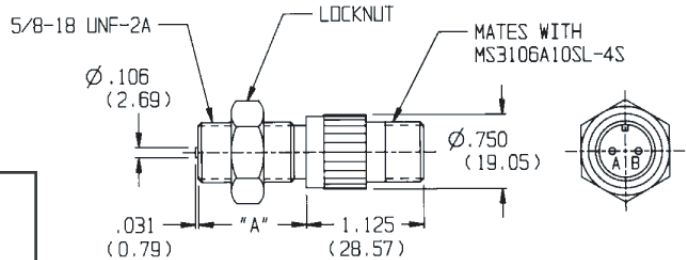
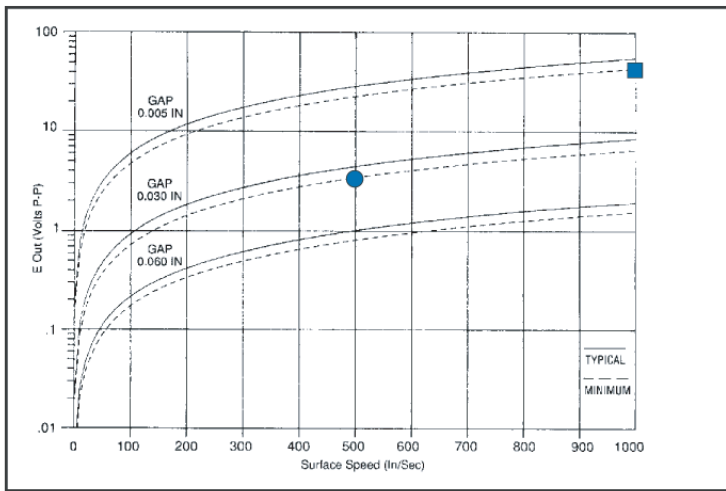

Specifications:

- Output Voltage (Standard): 40 V (P-P)
 - Output Voltage (Guarantee Point): 3.4 V (P-P)
- DC Resistance: 130 ohms max.
 Typical Inductance: 33 mH ref.
 Output Polarity: Pin 'B' positive
 Operating Temperature: -55 to +107°C
 Net Weight: 5 oz. max.

High Sensitivity

Ordering Part #	Thread Length (A)
70085-1010-002	1.125 (28.57)
70085-1010-175	2.625 (66.67)
70085-1010-026	3.625 (92.07)
70085-1010-408	5.000 (127.00)

(Select cable from group "A", see index)

Performance Curves

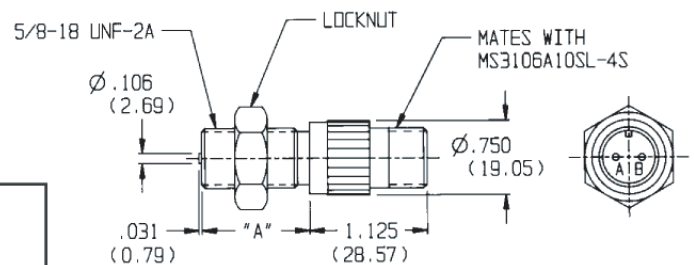
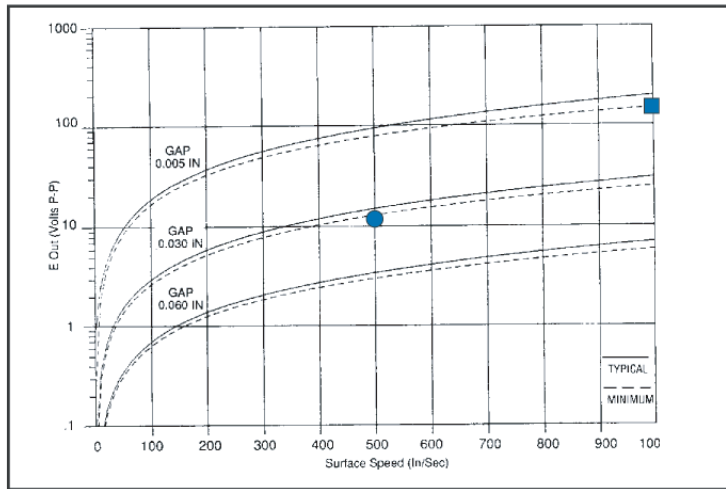

Specifications:

- Output Voltage (Standard): 150 V (P-P)
 - Output Voltage (Guarantee Point): 12.9 V (P-P)
- DC Resistance: 1500 ohms max.
 Typical Inductance: 360 mH ref.
 Output Polarity: Pin 'B' positive
 Operating Temperature: -55 to +107°C
 Net Weight: 5 oz. max.

Passive Speed Sensors

5/8 – 18 FAMILY

Power Output

Ordering Part # **Thread Length (A)**
 70085-1010-028 1.437 (36.50)
 (Select cable from group "A", see index)

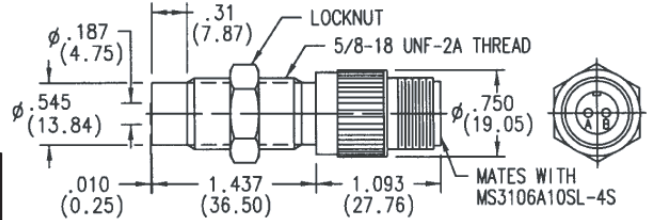

Performance Curves

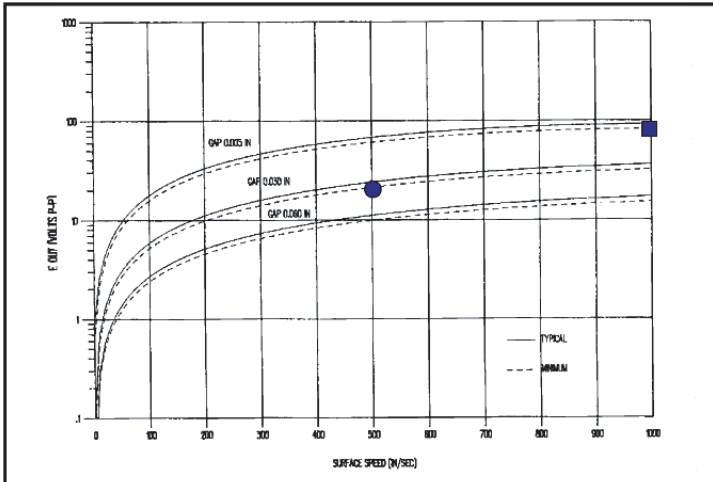

Based on 8 D.P. Gear

Specifications:

- Output Voltage (Standard): 75 V (P-P)
- Output Voltage (Guarantee Point): 21.5 V (P-P)
- DC Resistance: 210 ohms max.
- Typical Inductance: 50 to 95 mH ref.
- Output Polarity: Pin "B" positive
- Operating Temperature: -73 to +107° C
- Net Weight: 2.2 oz. max.

Conduit Fitting – General Purpose

Ordering Part # **Thread Length (A)**
 70085-1010-004 1.125 (28.57)
 70085-1010-469 2.750 (69.85)

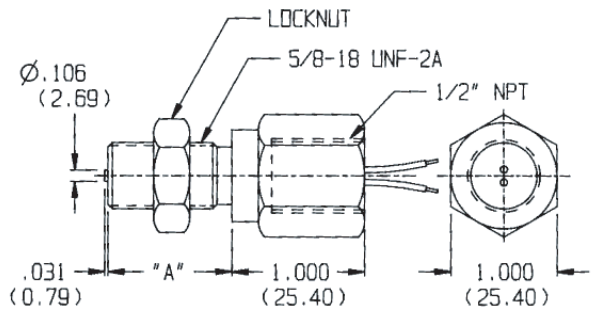

Performance Curves

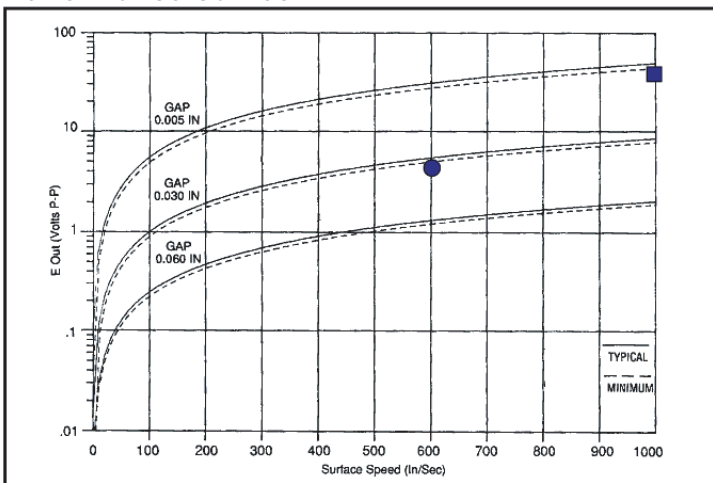

Based on 20 D.P. Gear

Specifications:

- Output Voltage (Standard): 43 V (P-P)
- Output Voltage (Guarantee Point): 4.3 V (P-P)
- DC Resistance: 130 ohms max.
- Typical Inductance: 32-46 mH ref.
- Output Polarity: Red lead positive
- Operating Temperature: -73 to +107° C
- Lead length: 10 ft (3.05 m)
- Net Weight: 16 oz. max.

Al-Tek Instruments, Cheshire, CT USA

Dimensions in inches and (mm).

Passive Speed Sensors

5/8 – 18 FAMILY

Full Thread – Power Output

Ordering Part #	Thread Length (A)
70085-1010-131	1.750 (44.45)
70085-1010-214	3.000 (76.20)

Performance Curves

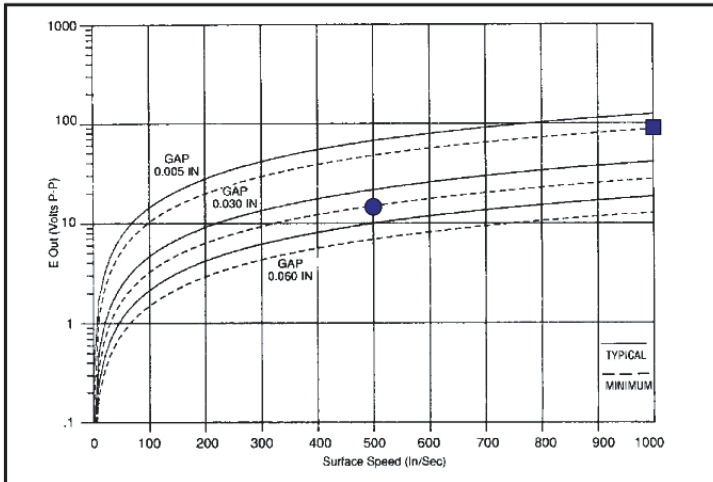

Based on 8 D.P. Gear

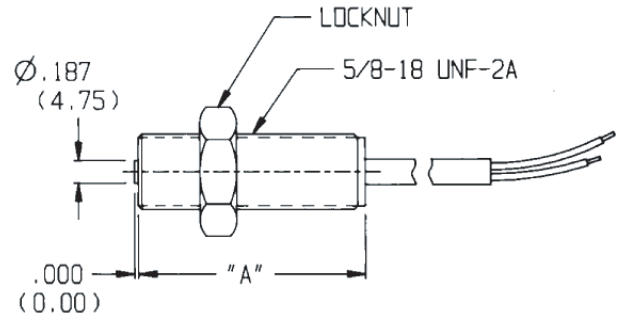

Specifications:

- Output Voltage (Standard): 120 V (P-P)
- Output Voltage (Guarantee Point): 15.1 V (P-P)
- DC Resistance: 220 ohms max.
- Typical Inductance: 40-60 mH ref.
- Output Polarity: White lead positive
- Operating Temperature: -55 to +107° C
- Cable Length: 10 ft (3.05 m)
- Net Weight: 5 oz. max.

Full Thread – General Purpose

Ordering Part #	Thread Length (A)
70085-1010-078	1.875 (47.62)
70085-1010-137	3.000 (76.20)

Performance Curves

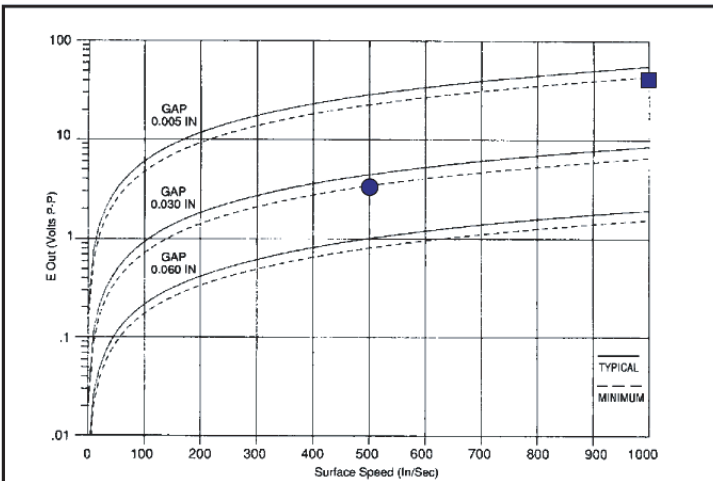

Based on 20 D.P. Gear

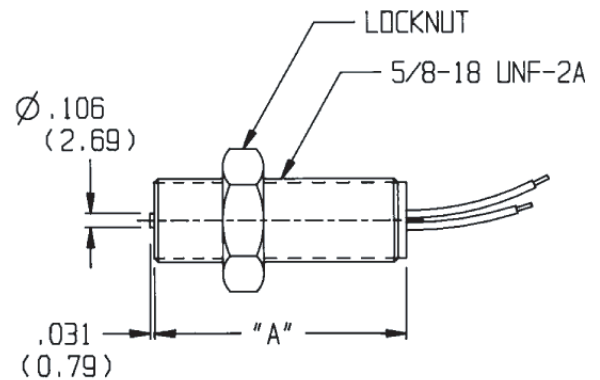

Specifications:

- Output Voltage (Standard): 40 V (P-P)
- Output Voltage (Guarantee Point): 3.4 V (P-P)
- DC Resistance: 130 ohms max.
- Typical Inductance: 33 mH ref.
- Output Polarity: white lead positive
- Operating Temperature: -55 to +107°C
- Lead Length: -078, 12 in (30.5 cm)
- 137, 24 in (60.9 cm)
- Net Weight: 3 oz. max.

AI-Tek Instruments, Cheshire, CT USA

Passive Speed Sensors

5/8 – 18 FAMILY

Full Thread – High Sensitivity

Ordering Part #	Thread Length (A)
70085-8080-003	1.812 (46.03)
70085-1010-220	3.000 (76.20)

Performance Curves

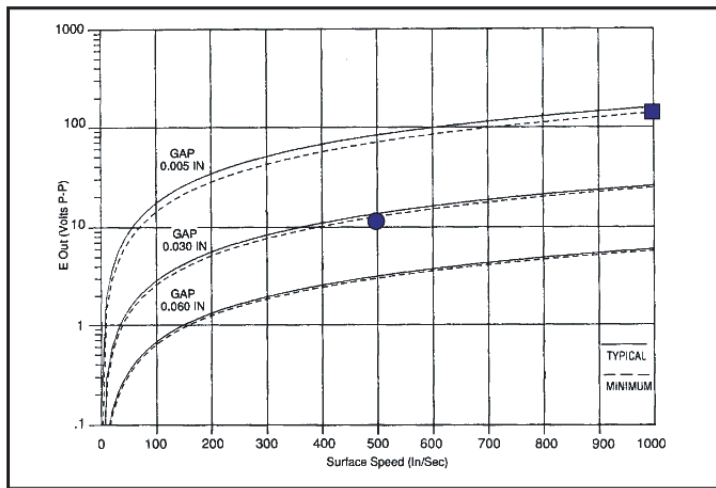

Based on 20 D.P. Gear

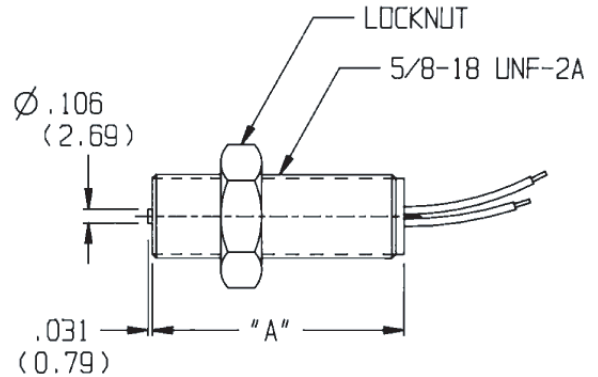

Specifications:

- Output Voltage (Standard): 150 V (P-P)
- Output Voltage (Guarantee Point): 12.8 V (P-P)
- DC Resistance: 1650 ohms max.
- Typical Inductance: 500 mH ref.
- Output Polarity: White lead positive
- Operating Temperature: -55 to +107°C
- Lead Length: -003, 12 in (30.5 cm)
- 220, 36 in (91.4 cm)
- Net Weight: 3 oz. max.

Molded – High Sensitivity

Ordering Part #	Thread Length (A)
70084-1713-111	1.125 (28.57)

(Select cable from group "A", see index)

Performance Curves

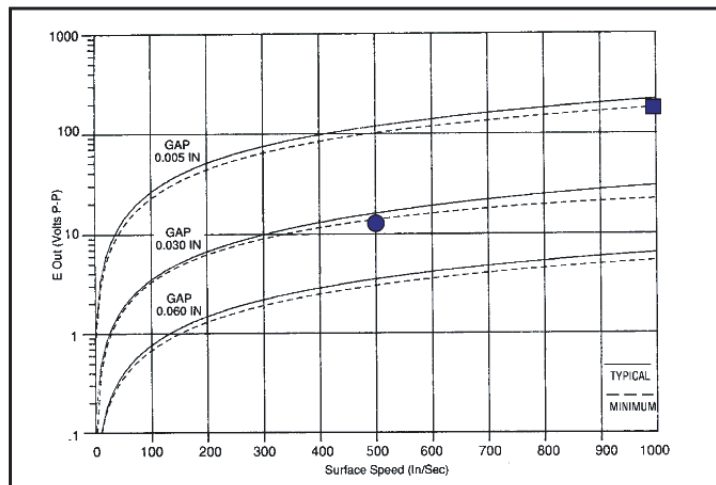

Based on 20 D.P. Gear

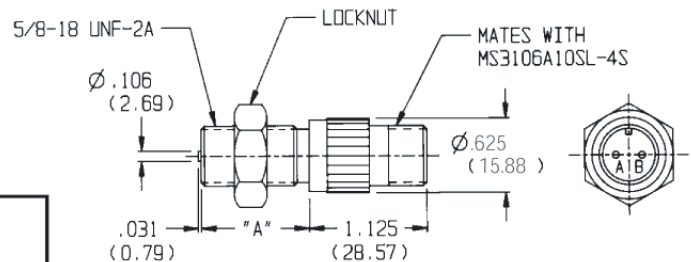

Specifications:

- Output Voltage (Standard): 190 V (P-P)
- Output Voltage (Guarantee Point): 13.9 V (P-P)
- DC Resistance: 1200 ohms max.
- Typical Inductance: 400 mH ref.
- Output Polarity: Pin 'B' positive
- Operating Temperature: -40 to +150°C
- Net Weight: 2 oz. max.

AI-Tek Instruments, Cheshire, CT USA

Dimensions in inches and (mm).

Passive Speed Sensors

5/8 – 18 FAMILY

Molded

Ordering Part #	Thread Length (A)
70085-1010-421	2.475 (62.87)
70085-1010-425	3.000 (76.20) * M16 x 1.5 Thd.
70085-1010-424	4.493 (114.12)

(Select cable from group "A", see index)

Performance Curves **

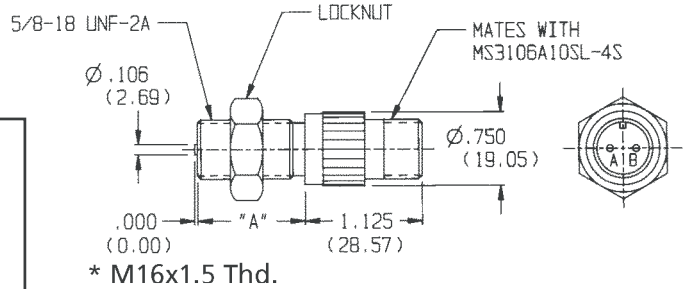
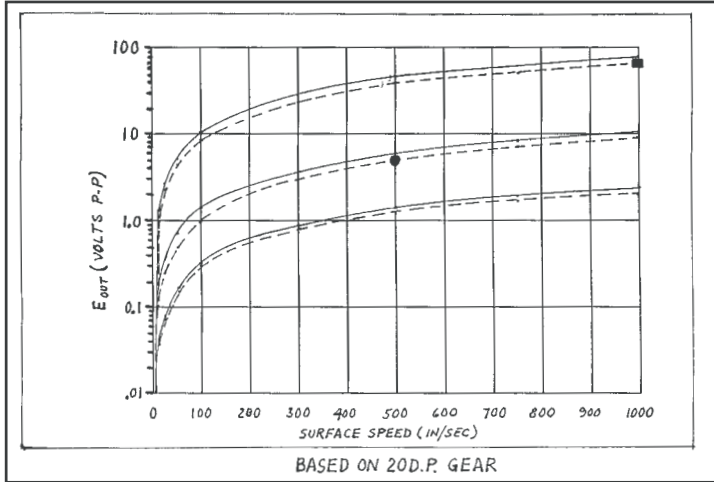

Specifications:

- Output Voltage (Standard): 63 V (P-P)
- Output Voltage (Guarantee Point): 4.9V (P-P)
- DC Resistance: 250 ohms max.
- Typical Inductance: 63 mH ref.
- Output Polarity: Pin 'B' positive
- Operating Temperature: -55 to +107° C
- Net Weight: 5 oz. max.

Passive Speed Sensors

3/8 – 24 FAMILY

General Purpose

Ordering Part #	Thread Length (A)
70085-1010-007	.812 (20.62)
70085-1010-056	3.500 (88.90)

Performance Curves

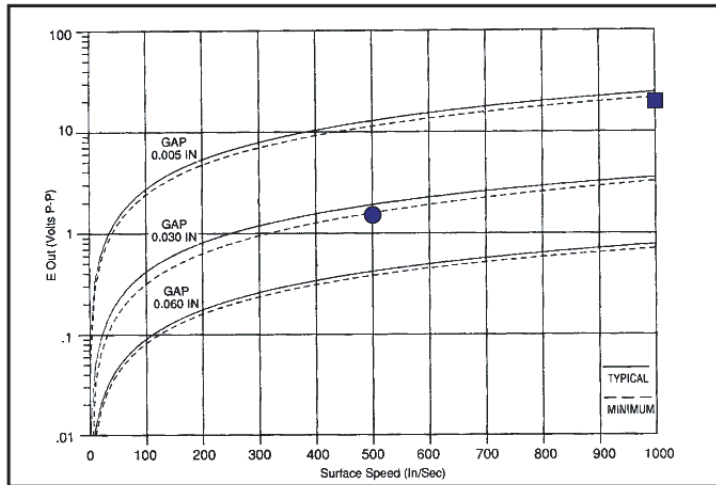

Based on 20 D.P. Gear

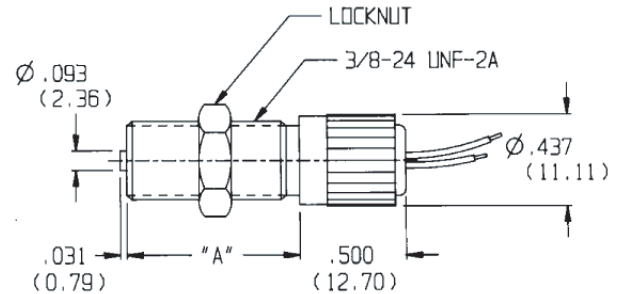

Specifications:

- Output Voltage (Standard): 21 V (P-P)
- Output Voltage (Guarantee Point): 1.6 V (P-P)
- DC Resistance: 115 ohms max.
- Typical Inductance: 22 mH ref.
- Output Polarity: White lead positive
- Operating Temperature: -55 to +107°C
- Lead Length: 6 in (15.2 cm)
- Net Weight: 2 oz. max.

High Sensitivity

Ordering Part #	Thread Length (A)
70085-1010-086	.812 (20.62)
70085-1010-355	.812 (20.62)

Performance Curves

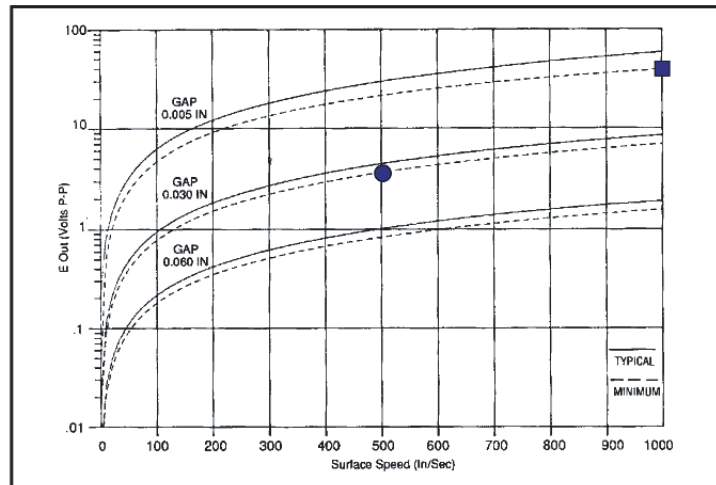

Based on 20 D.P. Gear

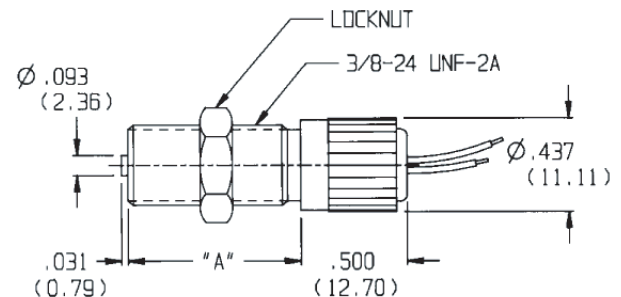

Specifications:

- Output Voltage (Standard): 55 V (P-P)
- Output Voltage (Guarantee Point): 3.6V (P-P)
- DC Resistance: 700 ohms max.
- Typical Inductance: 125 mH ref.
- Output Polarity: White lead positive
- Operating Temperature: -55 to +107°C
- Lead Length: -086, 18 in (45.7 cm)
- Cable Length: -355, 40 in (101.6 cm)
- Net Weight: 2 oz. max.

AI-Tek Instruments, Cheshire, CT USA

Dimensions in inches and (mm).

Passive Speed Sensors

3/8 – 24 FAMILY

General Purpose – High Temperature

Ordering Part #	Thread Length (A)	
70085-1010-041	.812	(20.62)
70085-1010-428	1.500	(38.10)
70085-1010-458	3.500	(88.90)

Performance Curves

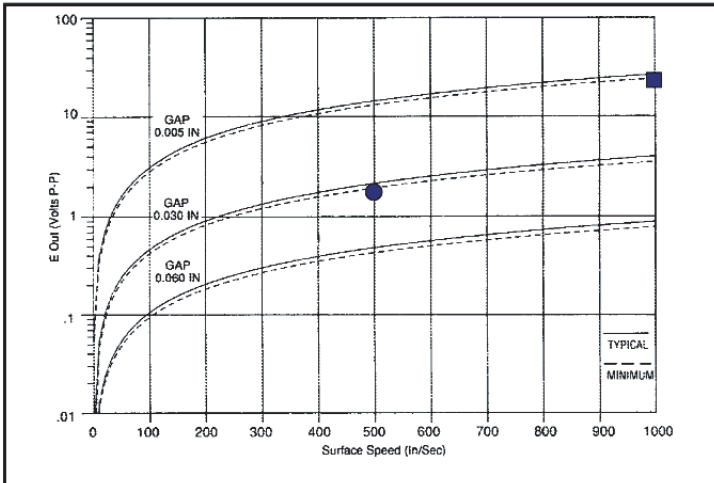

Based on 20 D.P. Gear

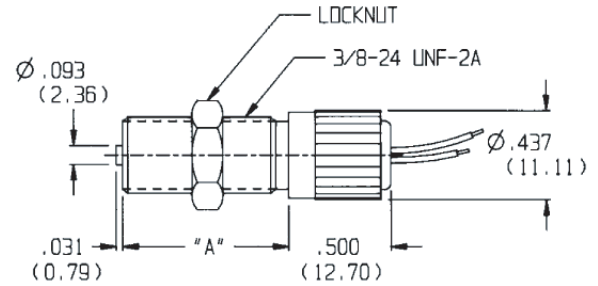

Specifications:

- Output Voltage (Standard): 24 V (P-P)
- Output Voltage (Guarantee Point): 2.0 V (P-P)
- DC Resistance: 110 ohms max.
- Typical Inductance: 21 mH ref.
- Output Polarity: White lead positive
- Operating Temperature: -73 to +232°C
- Lead Length: 40 in (1 m)
- Net Weight: 2 oz. max.

High Sensitivity - High Temperature

Ordering Part #	Thread Length (A)	
70085-1010-174	.812	(20.62)

Performance Curves

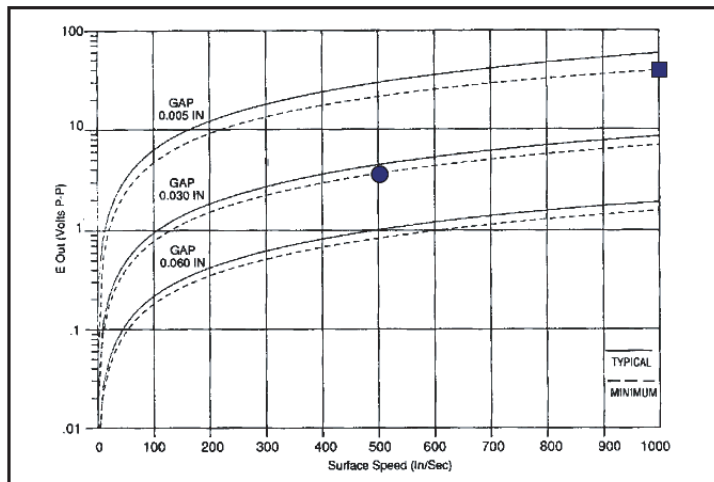

Based on 20 D.P. Gear

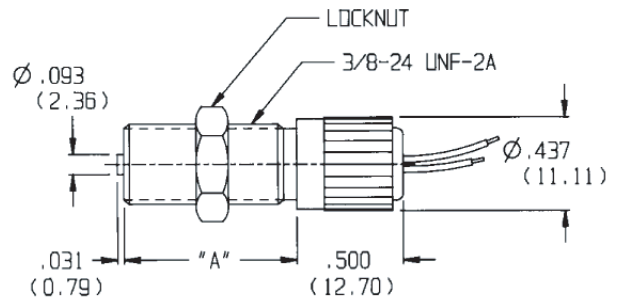

Specifications:

- Output Voltage (Standard): 55 V (P-P)
- Output Voltage (Guarantee Point): 3.6V (P-P)
- DC Resistance: 700 ohms max.
- Typical Inductance: 125 mH ref.
- Output Polarity: White lead positive
- Operating Temperature: -65 to +220°C
- Cable Length: 60 in (1.5 m)
- Net Weight: 2 oz. max.

AI-Tek Instruments, Cheshire, CT USA

Passive Speed Sensors

3/8 – 24 FAMILY

Full Thread – High Sensitivity

Ordering Part # Thread Length (A)
 70085-8080-001 1.500 (38.10)

Performance Curves

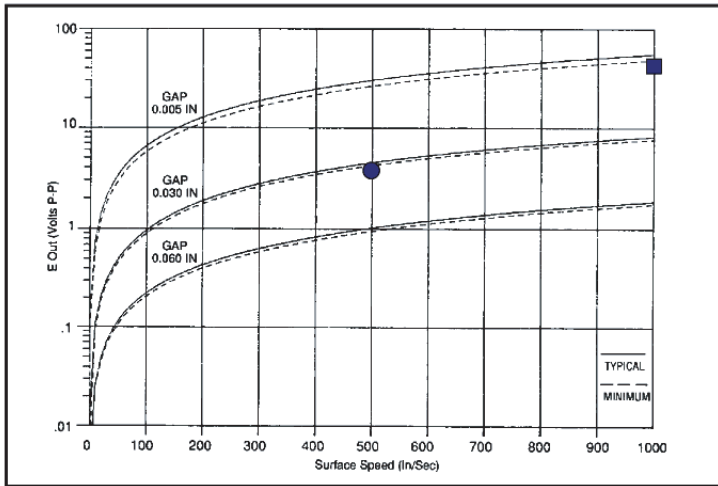

Based on 20 D.P. Gear

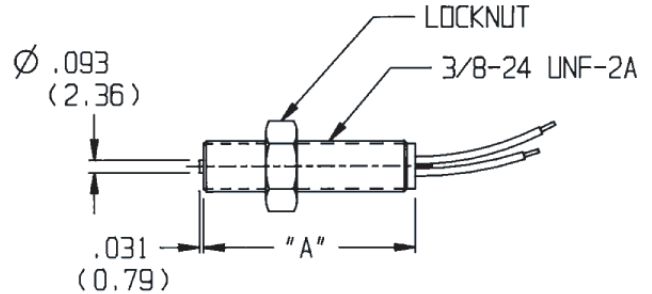

Specifications:

- Output Voltage (Standard): 55 V (P-P)
- Output Voltage (Guarantee Point): 4.2 V (P-P)
- DC Resistance: 700 ohms max.
- Typical Inductance: 125 mH ref.
- Output Polarity: White lead positive
- Operating Temperature: -55 to + 107°C
- Lead Length: 6 in (15.2cm)
- Net Weight: 1 oz. max.

Smooth Body – High Sensitivity

Ordering Part # Thread Length (A)
 70085-1010-314 1.375 (34.93)
 70085-8080-004 2.500 (63.50)

Performance Curves

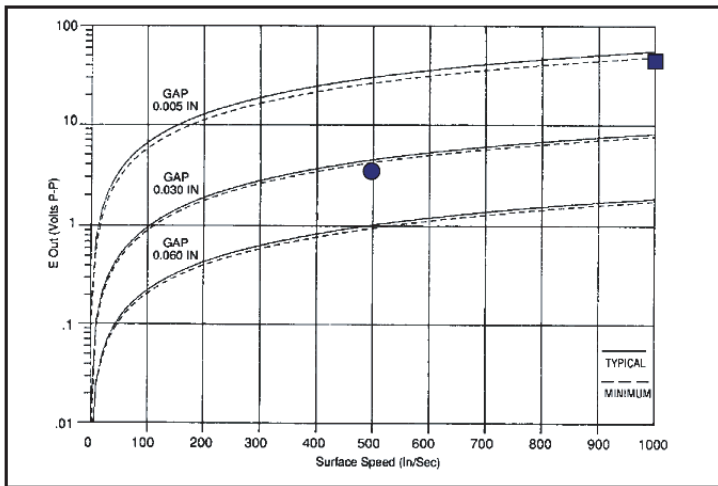

Based on 20 D.P. Gear

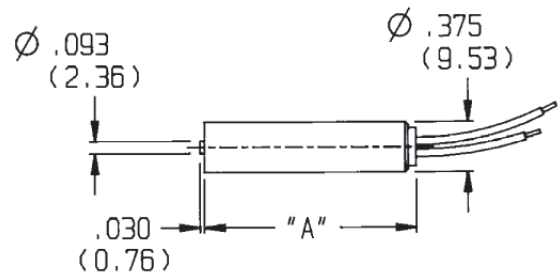

Specifications:

- Output Voltage (Standard): 55 V (P-P)
- Output Voltage (Guarantee Point): 4.2 V (P-P)
- DC Resistance: 700 ohms max.
- Typical Inductance: 125 mH ref.
- Output Polarity: White lead positive
- Operating Temperature: -30 to +85°C
- Lead Length: -004, 6 in (15.2cm)
- Cable Length: -314, 10ft (3.05m)
- Net Weight: 3 oz. max.

AI-Tek Instruments, Cheshire, CT USA

Dimensions in inches and (mm).

Passive Speed Sensors

1/4 – 40 FAMILY

General Purpose – High Temperature

Ordering Part #	Thread Length (A)	(B)
70085-1010-024	.687 (17.45)	.313 (7.95)
70085-1010-472 *	.687 (17.45)	.500 (12.70)
70085-1010-227	1.687 (42.85)	.313 (7.95)

Performance Curves

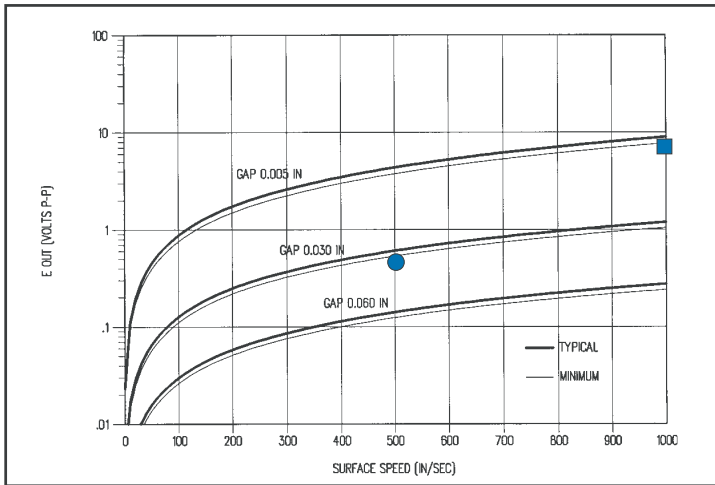

Based on 20 D.P. Gear

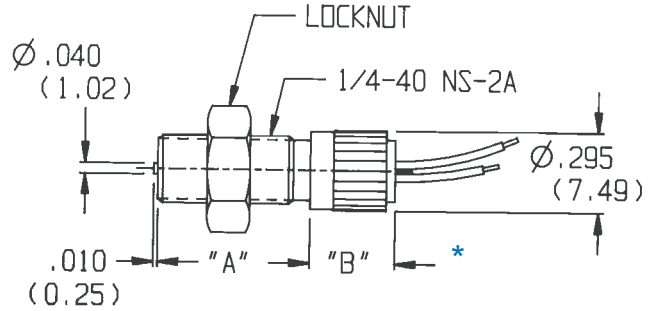

Specifications:

- Output Voltage (Standard): 4.7 V (P-P)
- Output Voltage (Guarantee Point): 0.4 V (P-P)
- DC Resistance: 125 ohms max.
- Typical Inductance: 5-12 mH ref.
- Output Polarity: White lead positive
- Operating Temperature: -73 to 232°C
- Lead Length: 8 in (20.3 cm)
- Cable Length: -472, 60 in (1.5 m) *
- Net Weight: 2 oz. max.

* Egress is a 2-conductor, AWG #26, shielded, Teflon cable, with 3.25" long shrink tubing over housing and cable for extra protection. Extra locknut provided.

Passive Speed Sensors

10 - 32 FAMILY

High Sensitivity

Ordering Part #	Thread Length (A)
70085-1010-037	.500 (12.70)
70085-1010-299	1.250 (31.75)

Performance Curves

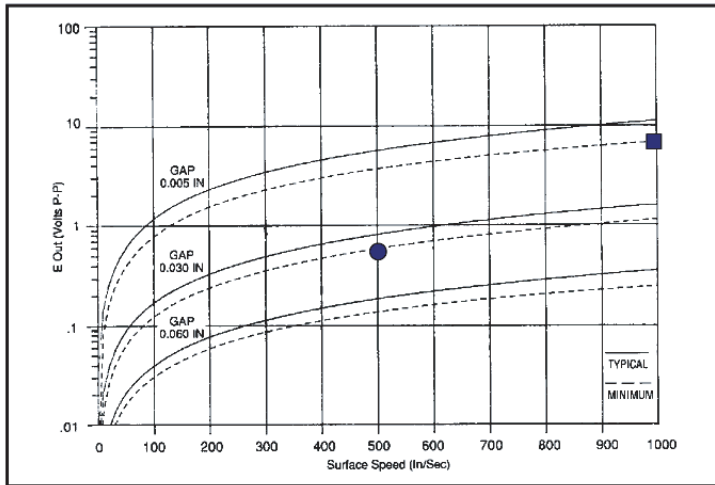

Based on 20 D.P. Gear

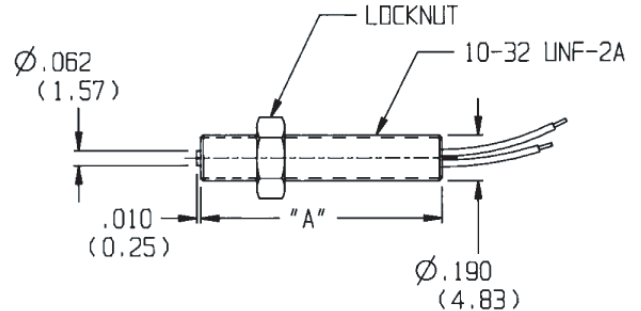

Specifications:

- Output Voltage (Standard): 13 V (P-P)
- Output Voltage (Guarantee Point): .6 V (P-P)
- DC Resistance: 190 ohms max.
- Typical Inductance: 10 mH, ref.
- Output Polarity: White lead positive
- Operating Temperature: -55 to +107°C
- Lead Length: 18 in (45.7 cm)
- Net Weight: 1 oz. max.

General Purpose – High Temperature

Ordering Part #	Thread Length (A)
70085-1010-182	.500 (12.70)
70085-1010-289	1.250 (31.75)

Performance Curves

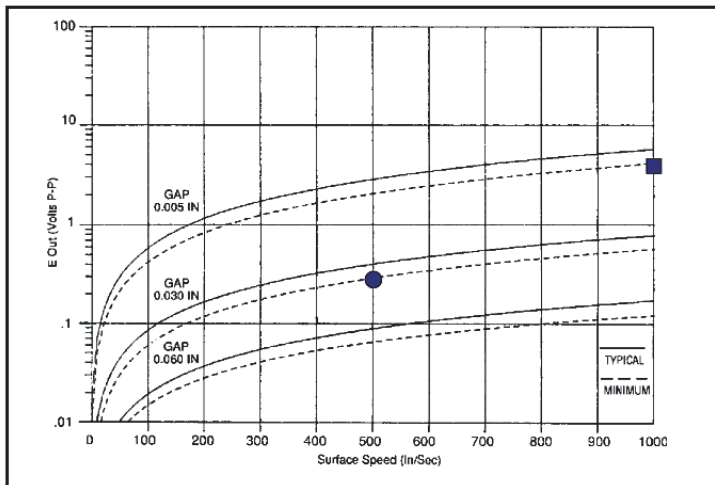

Based on 20 D.P. Gear

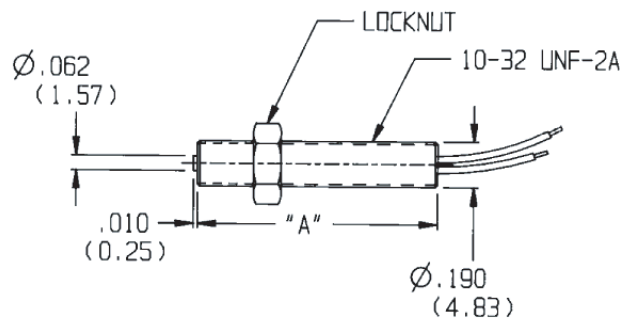

Specifications:

- Output Voltage (Standard): 6 V (P-P)
- Output Voltage (Guarantee Point): .3 V (P-P)
- DC Resistance: 45 ohms max.
- Typical Inductance: 2 mH, ref.
- Output Polarity: White lead positive
- Operating Temperature: -73 to +150°C
- Lead Length: 18 in (45.7 cm)
- Net Weight: 1 oz. max.

Al-Tek Instruments, Cheshire, CT USA

Dimensions in inches and (mm).

UL/CSA Sensors

Ordering Part #	Thread Length (A)	
70085-1010-081	1.500	(38.10)
70085-1010-411	1.875	(47.63)
70085-1010-329	2.750	(69.85)
70085-1010-330	4.000	(101.60)
70085-1010-412	6.000	(152.40)

Rating: UL and CSA listed for hazardous locations. Class I, Div 1, Groups A, B, C & D; Class II, Div 1, Groups E, F, G. Temp Code T3C.

Performance Curves

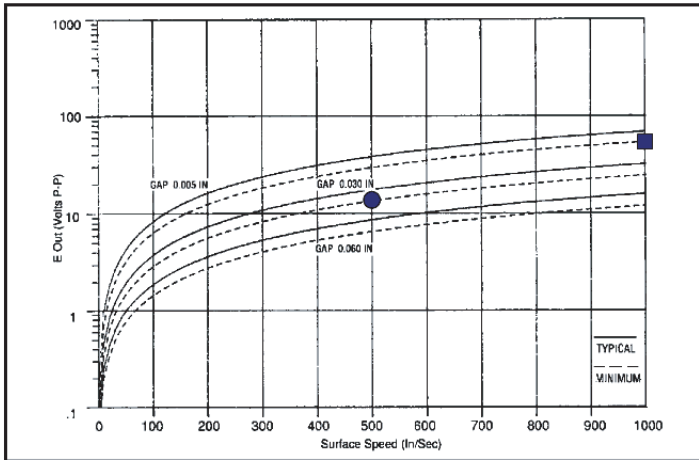

Based on 8 D.P. Gear

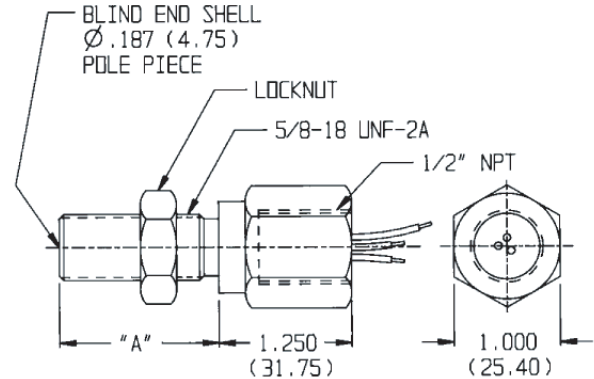

Specifications:

- Output Voltage (Standard): 54 V (P-P)
- Output Voltage (Guarantee Point): 13.4 V (P-P)
- DC Resistance: 240 ohms max.
- Typical Inductance: 30 mH ref.
- Output Polarity: White lead positive
- Operating Temperature: -65 to 100°C
- Lead Length: 10 ft (3.05 m)
- Housing Ground: Green/Yellow Tracer
- Net Weight: 14 oz. max.

UL/CSA Sensors

Ordering Part #	Thread Length (A)	
70085-1010-413	1.500	(38.10)
70085-1010-005	1.875	(47.63)
70085-1010-327	2.750	(69.85)
70085-1010-328	4.000	(101.60)
70085-1010-414	6.000	(152.40)

Rating: UL and CSA listed for hazardous locations. Class I, Div 1, Groups A, B, C & D; Class II, Div 1, Groups E, F, G. Temp Code T3C.

Performance Curves

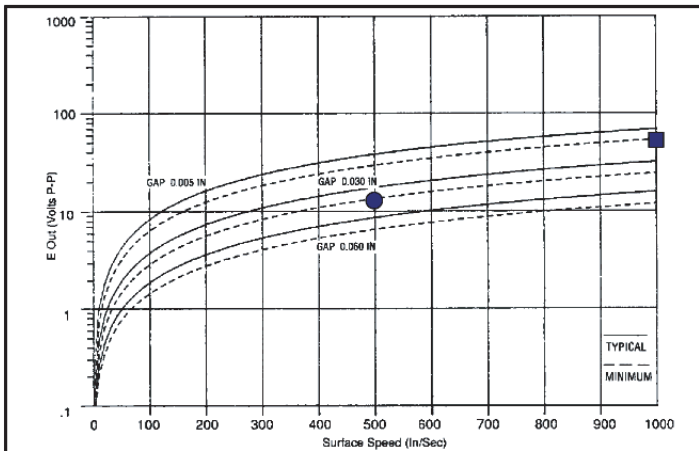

Based on 8 D.P. Gear

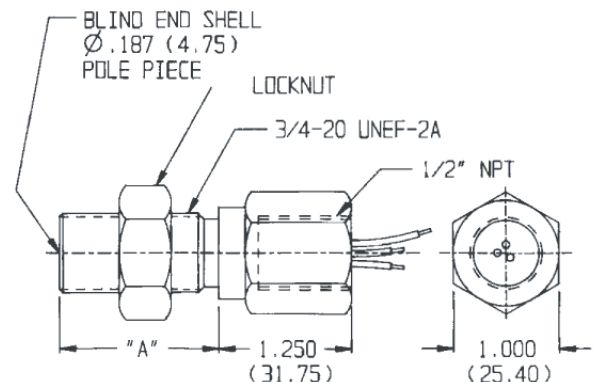

Specifications:

- Output Voltage (Standard): 54 V (P-P)
- Output Voltage (Guarantee Point): 13.4 V (P-P)
- DC Resistance: 240 ohms max.
- Typical Inductance: 30 mH ref.
- Output Polarity: White lead positive
- Operating Temperature: -65 to +100°C
- Lead Length: 10 ft (3.05 m)
- Housing Ground: Green/Yellow Tracer
- Net Weight: 14 oz. max.

Dimensions in inches and (mm).

UL/CSA Sensors

Ordering Part #	Thread Length (A)	
70085-1010-081	1.500	(38.10)
70085-1010-411	1.875	(47.63)
70085-1010-329	2.750	(69.85)
70085-1010-330	4.000	(101.60)
70085-1010-412	6.000	(152.40)

Rating: UL and CSA listed for hazardous locations. Class I, Div 1, Groups A, B, C & D; Class II, Div 1, Groups E, F, G. Temp Code T3C.

Performance Curves

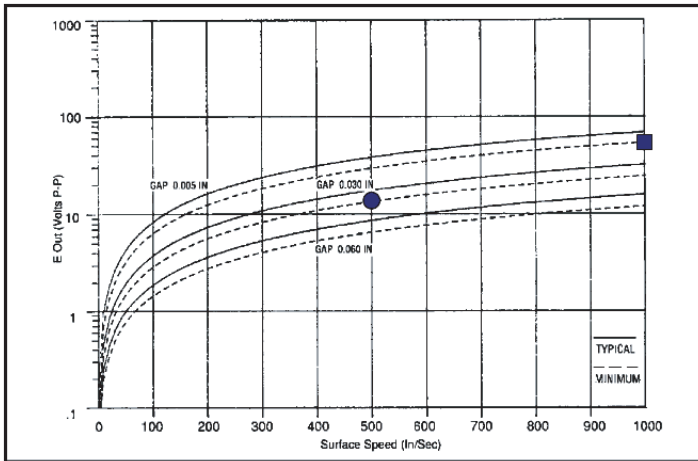

Based on 8 D.P. Gear

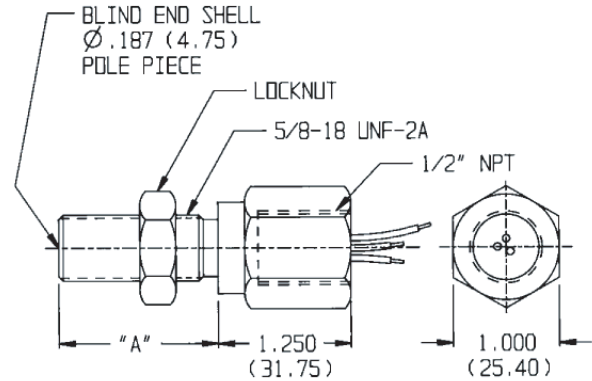

Specifications:

- Output Voltage (Standard): 54 V (P-P)
- Output Voltage (Guarantee Point): 13.4 V (P-P)
- DC Resistance: 240 ohms max.
- Typical Inductance: 30 mH ref.
- Output Polarity: White lead positive
- Operating Temperature: -65 to 100°C
- Lead Length: 10 ft (3.05 m)
- Housing Ground: Green/Yellow Tracer
- Net Weight: 14 oz. max.

UL/CSA Sensors

Ordering Part #	Thread Length (A)	
70085-1010-413	1.500	(38.10)
70085-1010-005	1.875	(47.63)
70085-1010-327	2.750	(69.85)
70085-1010-328	4.000	(101.60)
70085-1010-414	6.000	(152.40)

Rating: UL and CSA listed for hazardous locations. Class I, Div 1, Groups A, B, C & D; Class II, Div 1, Groups E, F, G. Temp Code T3C.

Performance Curves

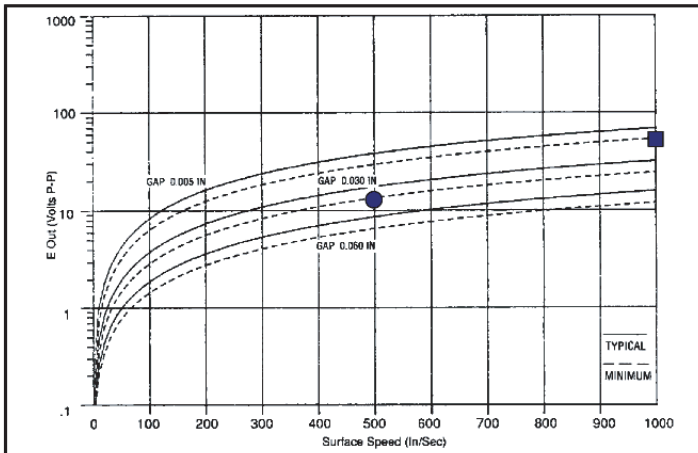

Based on 8 D.P. Gear

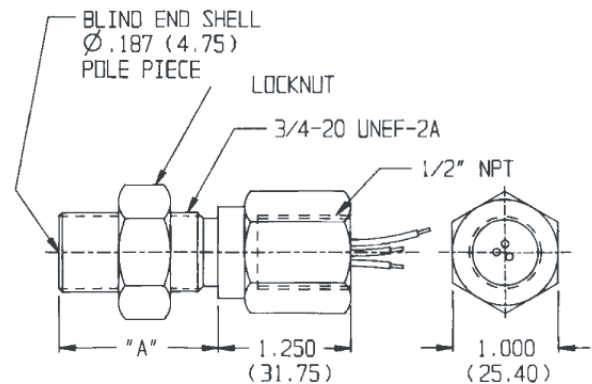

Specifications:

- Output Voltage (Standard): 54 V (P-P)
- Output Voltage (Guarantee Point): 13.4 V (P-P)
- DC Resistance: 240 ohms max.
- Typical Inductance: 30 mH ref.
- Output Polarity: White lead positive
- Operating Temperature: -65 to +100°C
- Lead Length: 10 ft (3.05 m)
- Housing Ground: Green/Yellow Tracer
- Net Weight: 14 oz. max.

Dimensions in inches and (mm).

AI-Tek Instruments, LLC

Side Look Sensor

Application: Used for Speed Take Off

The Side Look Sensor (SLS) has been developed by AI-Tek Instruments for Allison automatic transmissions for trucks ranging from light duty vans to over-the-road tractors. It is available for Allison AT, MT and HT transmissions. The new SLS improves on earlier designs developed for Allison to replace a mechanical speed system.

The SLS is a variable reluctance device that provides electronic transmission speed inputs to engine control systems and/or electronic dashboards. It mounts directly on the transmission and employs a unique magnet configuration that induces a magnetic field on the side of the sensor in the path of the rotating transmission gear. This system with its fewer mounting parts improves reliability, reduces weight and conserves space over the earlier designs.



The new SLS uses a molded, glass filled nylon body to protect the sensor in harsh, truck-operating environments. It replaces the old fly-lead design with an integral standard Packard connector, which eliminates the added extra connector cost of the old design. It is available in single and dual output versions.

The SLS is manufactured in the United States. AI-Tek Instruments Distributors stock the SLS for off-the-shelf maintenance, repair and overhaul (MRO) requirements.

Outline and Mounting Dimensions

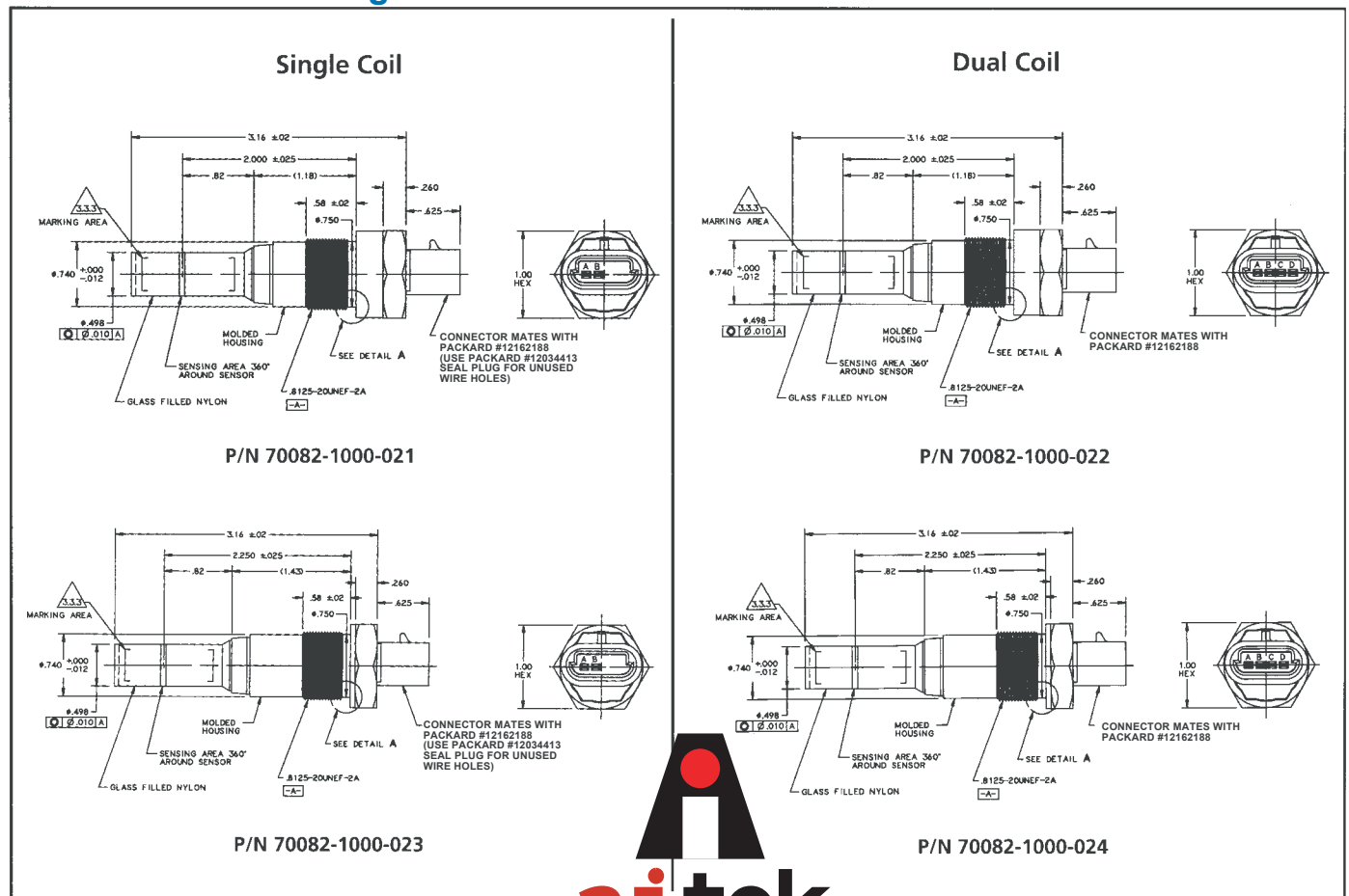

AI-Tek Instruments, Cheshire, CT USA



Specifications

Characteristics

Physical

Weight: 55 gm typical.
Body: Black, molded thermoplastic.

Electrical

All measurements at 25°C.

Output:

Single Coil: .67 Volts peak-to-peak, A to B
Dual Coil: .35 Volts peak-to-peak, A to B and C to D,
Sensing a 16 tooth wheel, 2.208" diameter
at 100 rpm and .040 inch air gap.

DC Resistance

Single Coil: 3.17K \pm 10% ohms.
Dual Coil: 1206 \pm 20% ohms each coil.

Inductance

Single Coil: 2.25 H typical.
Dual Coil: 620 mH typical.
Dielectric: 1000 VAC between terminals (shorted together) and body for 10 seconds .
.5 mA maximum leakage current.

Environmental

Temperature

Operating Temperature: -40°C to 150°C.
Storage Temperature: -40°C to 150°C.

Connector

Single Coil: Mates with Packard #12162188. (Use Packard #12034413 seal plug for unused wire holes.)
Dual Coil: Mates with Packard #12162188.

Single Coil

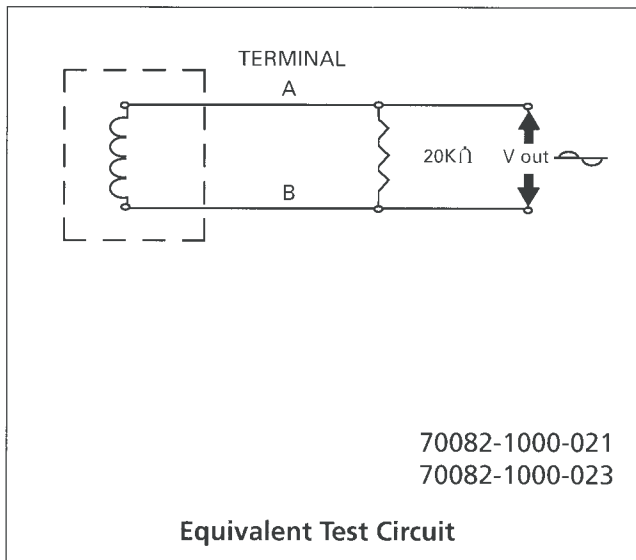

Dual Coil

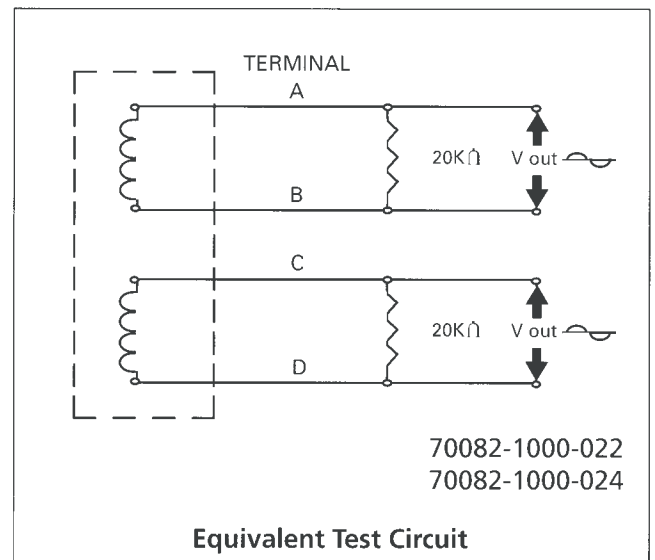

Applications

Applications	
P/N 70082-1000-021	AT, MT
P/N 70082-1000-022	AT, MT
P/N 70082-1000-023	HT
P/N 70082-1000-024	HT



a.i.tek

instruments

www.aitek-usa.com

(800) 576 - 6308

Distributed By **FLW** Inc.

Hall Effect Sensors

AI-Tek has taken its years of experience of designing and manufacturing Hall Effect sensors for engine timing applications and has developed a line of durable products for industrial use.

With multiple standard variations we offer the widest range of standard catalog sensors to meet your various design needs. The design is flexible to easily meet all of your application requirements.

The Hall Effect sensor can sense each change in target movement, regardless of speed, from near zero to 15 kHz frequency range, generating a steady pulse train of frequency proportional to target speed. Typically, each time a gear tooth (or any ferrous discontinuity) passes in front of the sensor the output changes state. This type of sensor is known as a “P” type because it uses N-P-N transistor logic (as opposed to “N” type, which uses P-N-P transistor logic).

Key features to note are:

- Reverse voltage protection, up to -30 Vdc, to prevent damage if miswired
- Higher temperature range of -40°C to +125°C
- Wide range of supply voltage in single design of 4.5 – 24 Vdc
- Two output options of Supply Tracking or TTL Compatible
- Rugged design meeting IEC 77 Standards (European Railroad Applications)

Suitable for 20 diametral pitch or coarser gear (target), the standard catalog sensors are easily applied to your varied sensing needs. If you have a unique, special requirement which cannot be met with any of the standard options, we will gladly review your specs and work with you on a special sensor design.

It is the customer's responsibility to determine whether the product is proper for customer's use and application.



Zero Velocity – Magnetic Hall Effect Sensors – 5/8 and 3/4 Threads

Specifications

Power Supply

Power Supply Voltage:

4.5 – 24 Vdc

Power Supply Current:

50 mA maximum

Outputs

Output Voltage:

Essentially square wave fanout to 10 TTL inputs

TTL Compatible: (See Figure 1)

50% ±30% duty cycle

Logic 0: +.6 Vdc maximum

Logic 1: +4 to +4.6 Vdc @ 5mA

Supply Tracking: (See Figure 2)

50% ±30% duty cycle

Logic 0: +.6 Vdc maximum

Logic 1:
$$V_O = \frac{V_S \times R_L}{R_L + 2.2k}$$

Output Impedance:

2.2K Ohms ±5%

Output Current:

20 mA sink maximum

Output Current - Short Circuit:

5 mA maximum with 10V power supply

Reverse Battery Voltage:

-30 Vdc

Mechanical

Target Frequency:

0 to 15 kHz

Target Air Gap:

.005 to .020 with a 20 diametral pitch gear

.005 to .045 with a 12 diametral pitch gear

.005 to .060 with a 8 diametral pitch gear

Environmental

Operating Temperature:

-40°C to +125°C

Thermal Shock:

100 cycles air to air (-40° to +130°C)

1 min. ramp time with 30 min. soak

Salt Spray:

Per MIL-STD-202, method 201, test cond. B, 5% NaCl for 48 hrs. No visible corrosion

Humidity:

92% RH@ 40°C for 90 hrs. No visible corrosion.

Dielectric Strength:

Per MIL-STD-202, method 301, 1000 Vrms (60Hz) for 5 sec. leads to case. 1.0 mA max. leakage.

Insulation Resistance:

Per MIL-STD-202, method 302, 500 Vdc for 30 sec. leads to case. 100 mega-ohm min.

Vibration:

Per MIL-STD-202, resonant frequency search, sine method 204, test cond. C&D (20g); random method 214a, test cond. A&B (7.56g) for 15 min.

Shock:

Per MIL-STD-202, method 213b (sawtooth), test cond. H&I (100g, 6 ms), 3 shocks, mutually perpendicular planes.

Materials

Housing:

300 series stainless steel

Leads:

AWG #24 Teflon, 200°C

Cable:

AWG #20 Irradiated cross-linked polyolefin, 125°C

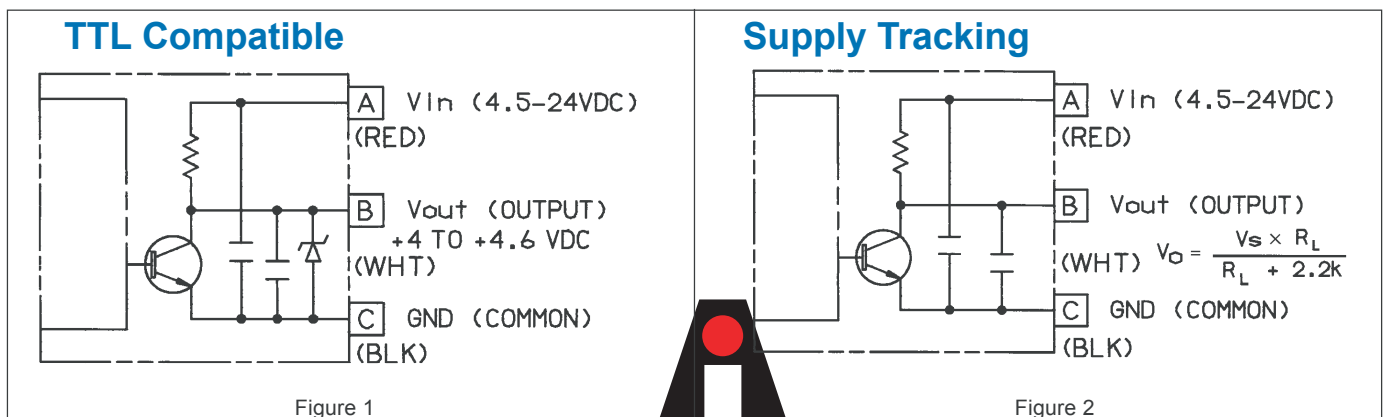

Note: Either output will work with any AI-Tek Tachometer

Zero Velocity – Magnetic Hall Effect Sensors – 5/8 and 3/4 Threads

Hex Body with Connector

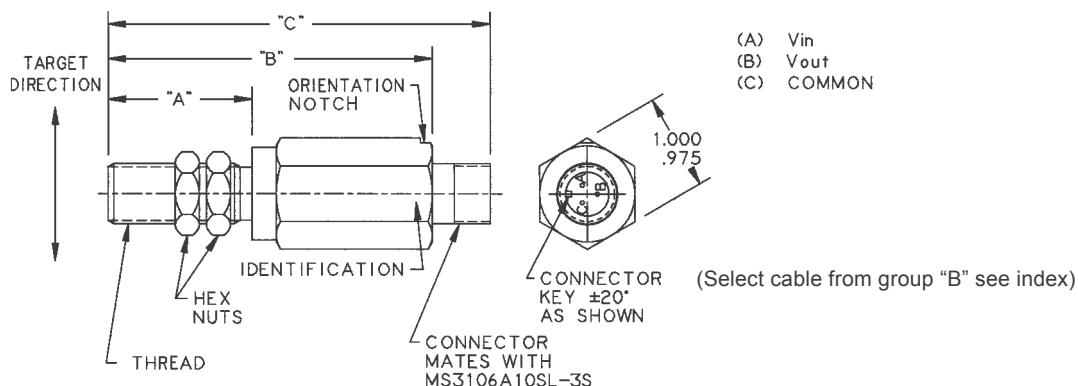

Part Num.	Thread	"A" Dimension	"B" Dimension	"C" Dimension	Output
H1512-001	.625-18 UNF-2A	1.500 (38.100)	3.375 (85.725)	4.012 (101.905)	TTL Compatible
H1522-001	.625-18 UNF-2A	1.500 (38.100)	3.375 (85.725)	4.012 (101.905)	Supply Tracking
H1512-002	.625-18 UNF-2A	2.750 (69.850)	4.625 (117.475)	5.262 (133.655)	TTL Compatible
H1522-002	.625-18 UNF-2A	2.750 (69.850)	4.625 (117.475)	5.262 (133.655)	Supply Tracking
H1612-001	.750-20 UNEF-2A	1.500 (38.100)	3.375 (85.725)	4.012 (101.905)	TTL Compatible
H1622-001	.750-20 UNEF-2A	1.500 (38.100)	3.375 (85.725)	4.012 (101.905)	Supply Tracking
H1612-002	.750-20 UNEF-2A	2.750 (69.850)	4.625 (117.475)	5.262 (133.655)	TTL Compatible
H1622-002	.750-20 UNEF-2A	2.750 (69.850)	4.625 (117.475)	5.262 (133.655)	Supply Tracking

Net Weight: 9 oz. max.

Hex Body with Cable

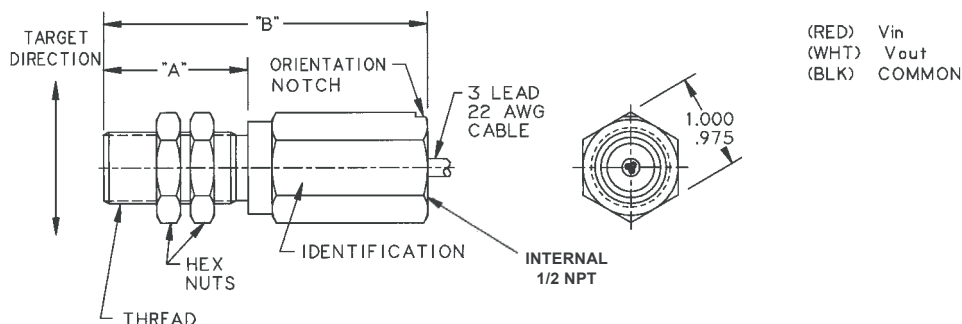

Part Num.	Thread	"A" Dimension	"B" Dimension	Cable Length	Output
H1512-013	.625-18 UNF-2A	1.500 (38.100)	3.375 (85.725)	10 ft (3.05m)	TTL Compatible
H1522-013	.625-18 UNF-2A	1.500 (38.100)	3.375 (85.725)	10 ft (3.05m)	Supply Tracking
H1512-014	.625-18 UNF-2A	2.750 (69.850)	4.625 (117.475)	10 ft (3.05m)	TTL Compatible
H1522-014	.625-18 UNF-2A	2.750 (69.850)	4.625 (117.475)	10 ft (3.05m)	Supply Tracking
H1612-013	.750-20 UNEF-2A	1.500 (38.100)	3.375 (85.725)	10 ft (3.05m)	TTL Compatible
H1622-013	.750-20 UNEF-2A	1.500 (38.100)	3.375 (85.725)	10 ft (3.05m)	Supply Tracking
H1612-014	.750-20 UNEF-2A	2.750 (69.850)	4.625 (117.475)	10 ft (3.05m)	TTL Compatible
H1622-014	.750-20 UNEF-2A	2.750 (69.850)	4.625 (117.475)	10 ft (3.05m)	Supply Tracking

Net Weight: 9 oz. max.

Dimensions in inches and (mm).

Zero Velocity – Magnetic Hall Effect Sensors – 5/8 and 3/4 Threads

Round Body with Connector

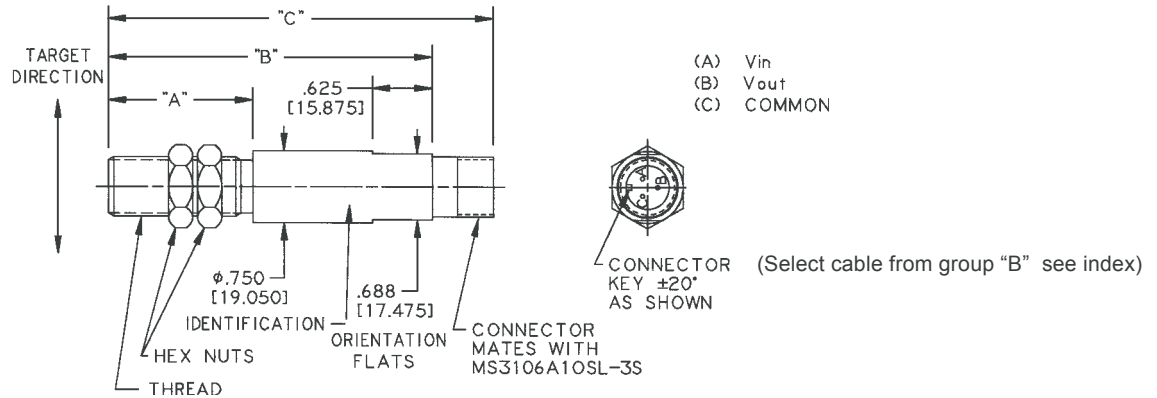

Part Num.	Thread	"A" Dimension	"B" Dimension	"C" Dimension	Output
H1512-005	.625-18 UNF-2A	1.500 (38.100)	3.375 (85.725)	4.012 (101.905)	TTL Compatible
H1522-005	.625-18 UNF-2A	1.500 (38.100)	3.375 (85.725)	4.012 (101.905)	Supply Tracking
H1512-006	.625-18 UNF-2A	2.750 (69.850)	4.625 (117.475)	5.262 (133.655)	TTL Compatible
H1522-006	.625-18 UNF-2A	2.750 (69.850)	4.625 (117.475)	5.262 (133.655)	Supply Tracking
H1512-007	.625-18 UNF-2A	4.000 (101.600)	5.875 (149.225)	6.512 (165.405)	TTL Compatible
H1522-007	.625-18 UNF-2A	4.000 (101.600)	5.875 (149.225)	6.512 (165.405)	Supply Tracking
H1612-005	.750-20 UNEF-2A	1.500 (38.100)	3.375 (85.725)	4.012 (101.905)	TTL Compatible
H1622-005	.750-20 UNEF-2A	1.500 (38.100)	3.375 (85.725)	4.012 (101.905)	Supply Tracking
H1612-006	.750-20 UNEF-2A	2.750 (69.850)	4.625 (117.475)	5.262 (133.655)	TTL Compatible
H1622-006	.750-20 UNEF-2A	2.750 (69.850)	4.625 (117.475)	5.262 (133.655)	Supply Tracking
H1612-007	.750-20 UNEF-2A	4.000 (101.600)	5.875 (149.225)	6.512 (165.405)	TTL Compatible
H1622-007	.750-20 UNEF-2A	4.000 (101.600)	5.875 (149.225)	6.512 (165.405)	Supply Tracking

Net Weight: 7 oz. max.

Fully Threaded with Leads

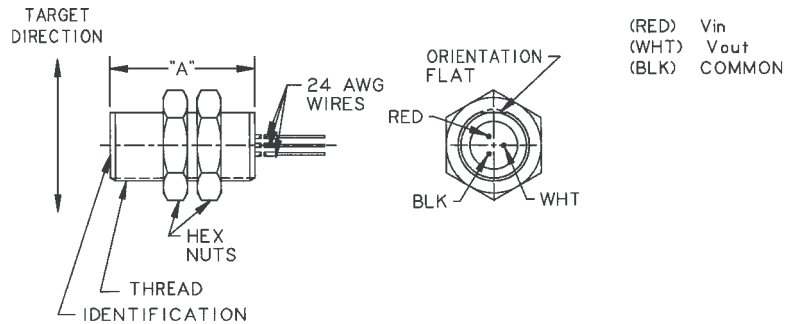

Part Num.	Thread	"A" Dimension	Lead Length	Output
H1512-009	.625-18 UNF-2A	1.500 (38.100)	12 (304)	TTL Compatible
H1522-009	.625-18 UNF-2A	1.500 (38.100)	12 (304)	Supply Tracking
H1512-010	.625-18 UNF-2A	2.750 (69.850)	12 (304)	TTL Compatible
H1522-010	.625-18 UNF-2A	2.750 (69.850)	12 (304)	Supply Tracking
H1612-009	.750-20 UNEF-2A	1.500 (38.100)	12 (304)	TTL Compatible
H1622-009	.750-20 UNEF-2A	1.500 (38.100)	12 (304)	Supply Tracking
H1612-010	.750-20 UNEF-2A	2.750 (69.850)	12 (304)	TTL Compatible
H1622-010	.750-20 UNEF-2A	2.750 (69.850)	12 (304)	Supply Tracking

Net Weight: 3 oz. max.

Zero Velocity – Magnetic Hall Effect Sensors – 5/8 and 3/4 Threads

UL/CSA Explosion Proof Sensors

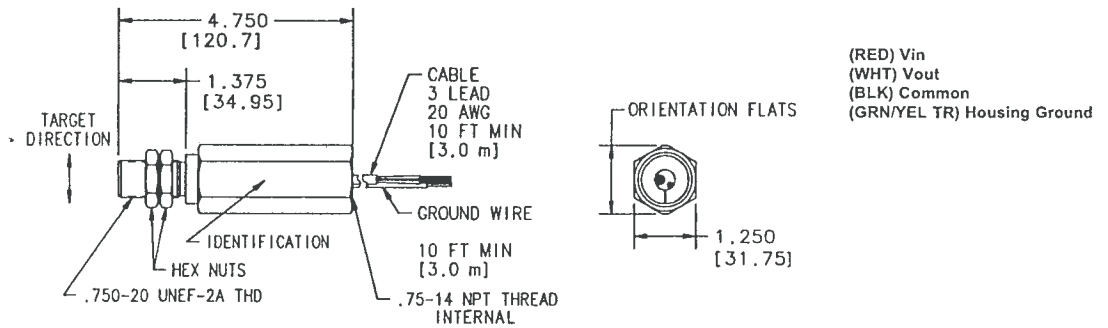

Part Num.	Thread	Thread Length	Overall Length	Cable Length	Output
H1612-025	.750-20 UNEF-2A	1.375 (34.92)	4.750 (120.65)	10 ft. (3.0 m)	TTL Compatible

Rating: UL & CSA listed for hazardous locations. Class I, Div. 1, Groups A, B, C & D; Class II, Div., 1, Groups E, F & G. Temp Code T4A. Connect only to NEC Class 2 circuits.
Net Weight: 23 oz. max.

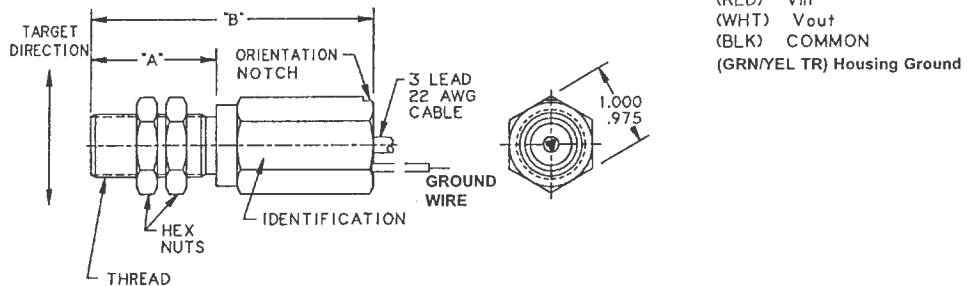

Part Num.	Thread	"A" Dimension	"B" Dimension	Cable Length	Output
H1512-026	.625-18 UNF-2A	1.500 (38.100)	3.375 (85.725)	10 ft (3.05m)	TTL Compatible
H1522-026	.625-18 UNF-2A	1.500 (38.100)	3.375 (85.725)	10 ft (3.05m)	Supply Tracking
H1512-027	.625-18 UNF-2A	2.750 (69.850)	4.625 (117.475)	10 ft (3.05m)	TTL Compatible
H1522-027	.625-18 UNF-2A	2.750 (69.850)	4.625 (117.475)	10 ft (3.05m)	Supply Tracking
H1612-026	.750-20 UNEF-2A	1.500 (38.100)	3.375 (85.725)	10 ft (3.05m)	TTL Compatible
H1622-026	.750-20 UNEF-2A	1.500 (38.100)	3.375 (85.725)	10 ft (3.05m)	Supply Tracking
H1612-027	.750-20 UNEF-2A	2.750 (69.850)	4.625 (117.475)	10 ft (3.05m)	TTL Compatible
H1622-027	.750-20 UNEF-2A	2.750 (69.850)	4.625 (117.475)	10 ft (3.05m)	Supply Tracking

Rating: UL & CSA listed for hazardous locations. Class I, Div. 1, Groups A, B, C & D; Class II, Div., 1, Groups E, F & G. Temp Code T4A. Connect only to NEC Class 2 circuits.
Net Weight: 9 oz. max.

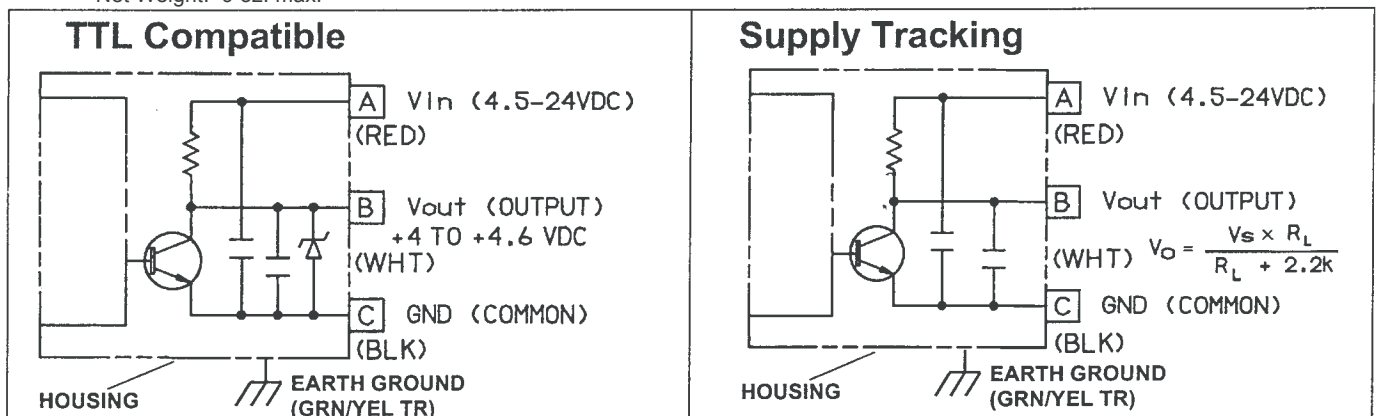

AI-Tek Instruments, Cheshire, CT USA

Dimensions in inches and (mm).

Zero Velocity – Magnetic Hall Effect Sensors – 3/8 Diameter

Specifications

Power Supply

Power Supply Voltage:

4.5 – 24 Vdc

Power Supply Current:

50 mA maximum

Outputs

Output Voltage:

Essentially square wave fanout to 10 TTL inputs

Supply Tracking: (See Figure 1)

50% ±30% duty cycle

Logic 0: +.6 Vdc maximum

Logic 1: $V_O = \frac{V_S \times R_L}{R_L + 2.2k}$

Output Impedance:

2.2K Ohms ±5%

Output Current:

20 mA sink maximum

Output Current - Short Circuit:

5 mA maximum with 10V power supply

Reverse Battery Voltage:

-30 Vdc

Mechanical

Target Frequency:

0 to 15 kHz

Target Air Gap:

.000 to .015 with a 20 diametral pitch gear

.000 to .040 with a 12 diametral pitch gear

.000 to .055 with a 8 diametral pitch gear

Environmental

Operating Temperature:

-25°C to +125°C (105°C Cable)

Materials

Housing:

300 series stainless steel

Leads:

AWG #24 Teflon, 200°C

Cable:

AWG #26 PVC, 105°C

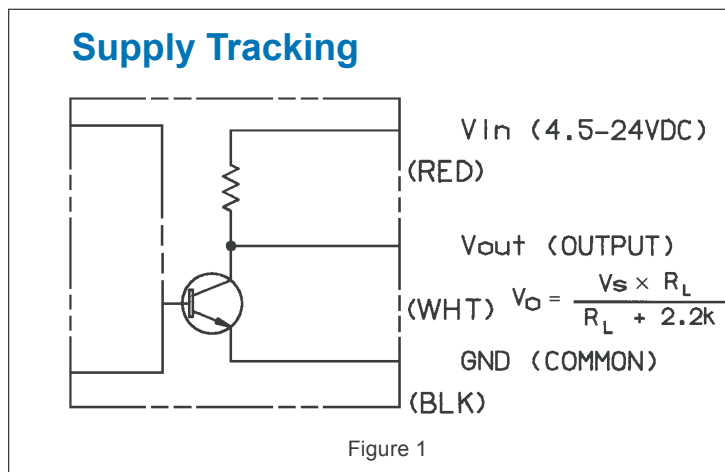

Note: Will work with any AI-Tek Tachometer.

Zero Velocity – Magnetic Hall Effect Sensors – 3/8 Diameter

Fully Threaded

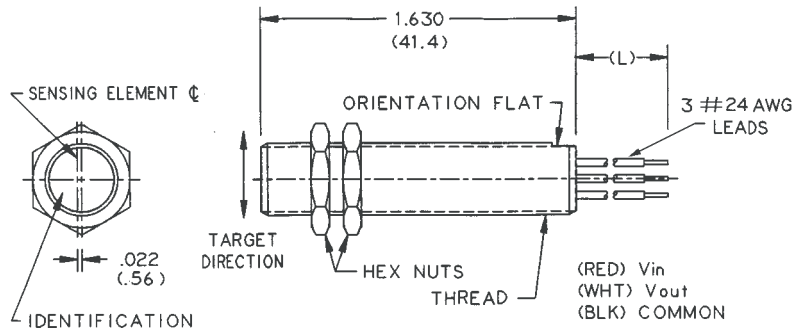

Part Num.	Thread	Cable Length (C)	Lead Length (L)
H1320-001	.375-32 UNEF-2A	—	12 (304)
H1320-003	.375-32 UNEF-2A	10 ft. (3.05 m)	—
H1320-009	.375-24 UNF-2A	—	12 (304)
H1320-010	.375-24 UNF-2A	10 ft. (3.05 m)	—

Net Weight: 0.7 oz. max.

Round Body

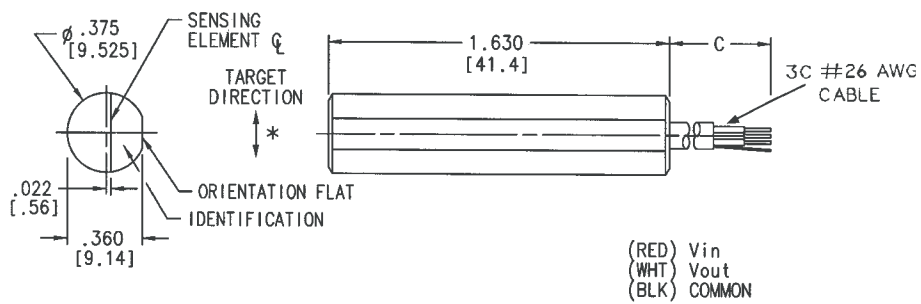

Part Number	Cable Length (C)	Lead Length (L)
H1320-005	—	12 (304)
H1320-006	10 ft (3.05 m)	—

Net Weight: 0.5 oz. max.

* Note difference in target direction with regard to flat (vs. threaded sensor).

Dimensions in inches and (mm).

Bi-Directional, Dual Channel, Hall Effect Speed Sensors

AI-Tek bi-directional, zero velocity sensors are self-calibrating to the specific customer application and provide two independent frequency outputs and a direction signal output to indicate change in direction of the sensed, ferrous target.

The bi-directional sensor can also be referred to as a dual channel sensor since it utilizes two Hall effect sensing elements, physically offset from each other. Each element generates a single channel of target information, identical in frequency and polarity, but offset in the time domain (phase shifted). Special circuits inside the sensor are designed to calibrate each channel to its application target, then analyze these two channels of information for a phase lead / lag condition. The direction output will then provide a logic 1 level for clockwise or a logic 0 level for counterclockwise rotation, assuming proper sensor orientation.

UL/CSA/ATEX

AI-Tek will be pursuing UL/CSA/ATEX approval for its line of Bi-Directional, Dual Channel, Hall Effect speed sensors.

Please contact Factory or Distributor for the status of this approval.

It is the customer's responsibility to determine whether the product is proper for customer's use and application.

Bi-Directional, Dual Channel, Hall Effect Speed Sensors

AI-Tek bi-directional, zero velocity sensors are self-calibrating to the specific customer application and provide two independent frequency outputs and a direction signal output to indicate change in direction of the sensed, ferrous target.

The bi-directional sensor can also be referred to as a dual channel sensor since it utilizes two Hall effect sensing elements, physically offset from each other. Each element generates a single channel of target information, identical in frequency and polarity, but offset in the time domain (phase shifted). Special circuits inside the sensor are designed to calibrate each channel to its application target, then analyze these two channels of information for a phase lead / lag condition. The direction output will then provide a logic 1 level for clockwise or a logic 0 level for counterclockwise rotation, assuming proper sensor orientation.

UL/CSA/ATEX

AI-Tek will be pursuing UL/CSA/ATEX approval for its line of Bi-Directional, Dual Channel, Hall Effect speed sensors.

Please contact Factory or Distributor for the status of this approval.

It is the customer's responsibility to determine whether the product is proper for customer's use and application.

Bi-Directional, Dual Channel, Hall Effect Speed Sensors - 5/8 and 3/4 Threads

Bi-Directional, Hex Body with 6 Pin Connector

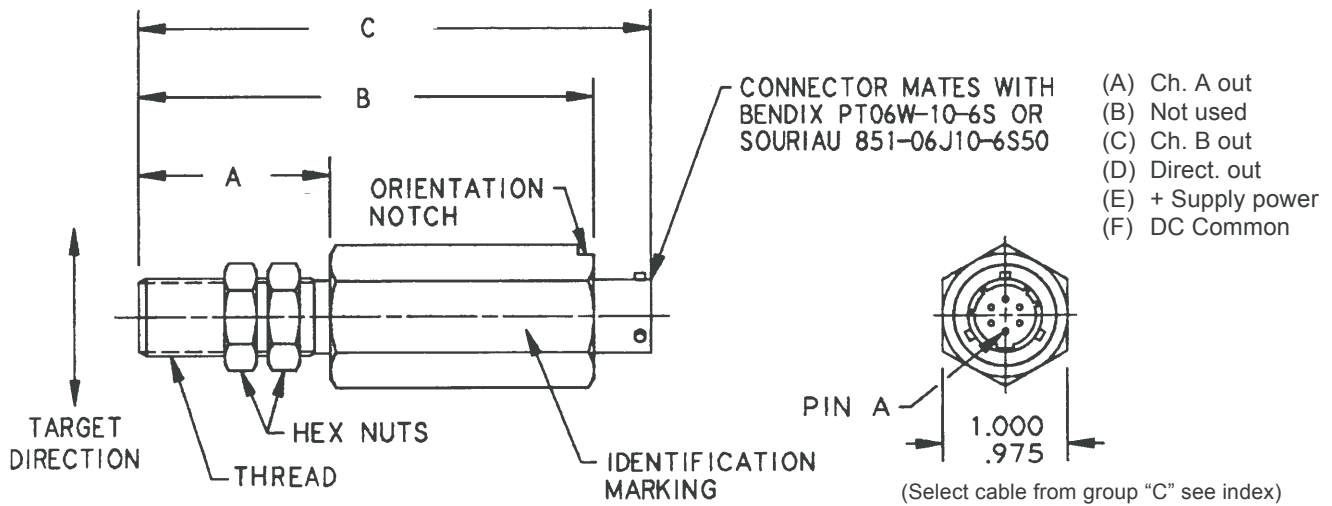

Part Num.	Thread	"A" Dim.	"B" Dim.	"C" Dim. (max.)	Output
BH1512-001	.625-18UNF-2A	1.500 (38.1)	3.375 (85.7)	3.875 (98.4)	TTL Compatible
BH1522-001					Supply Tracking
BH1512-002		2.750 (69.9)	4.625 (117.5)	5.125 (130.2)	TTL Compatible
BH1522-002					Supply Tracking
BH1612-001	.750-20UNEF-2A	1.500 (38.1)	3.375 (85.7)	3.875 (98.4)	TTL Compatible
BH1622-001					Supply Tracking
BH1612-002		2.750 (69.9)	4.625 (117.5)	5.125 (130.2)	TTL Compatible
BH1622-002					Supply Tracking

Bi-Directional, Hex Body with Cable

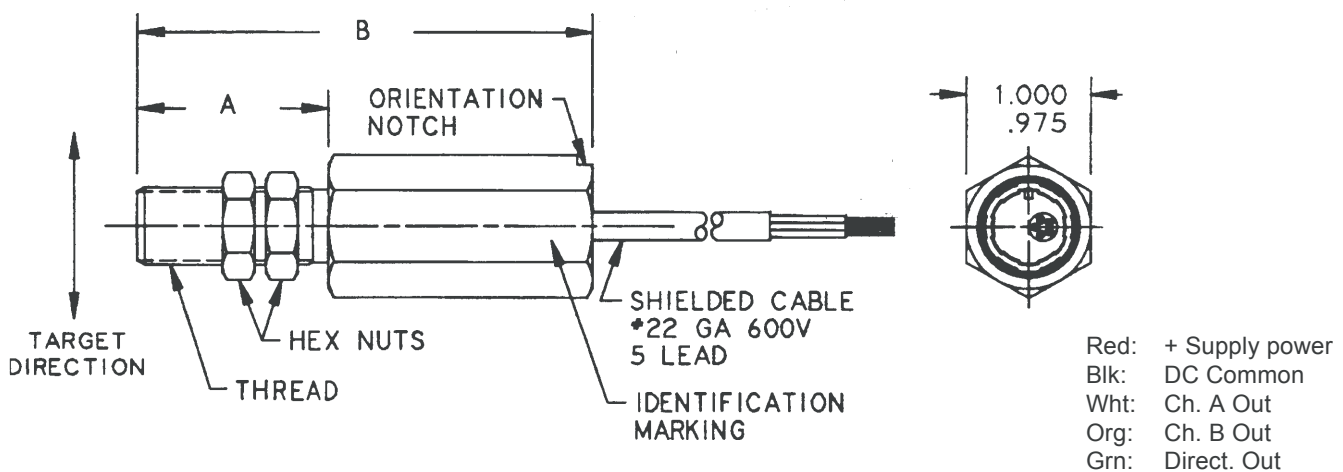

Part Num.	Thread	"A" Dim.	"B" Dim.	Cable Length	Output
BH1512-013	.625-18UNF-2A	1.500 (38.1)	3.375 (85.7)	10 ft. (3.05m)	TTL Compatible
BH1522-013					Supply Tracking
BH1512-014		2.750 (69.9)	4.625 (117.5)		TTL Compatible
BH1522-014					Supply Tracking
BH1612-013	.750-20UNEF-2A	1.500 (38.1)	3.375 (85.7)	10 ft. (3.05m)	TTL Compatible
BH1622-013					Supply Tracking
BH1612-014		2.750 (69.9)	4.625 (117.5)		TTL Compatible
BH1622-014					Supply Tracking

Bi-Directional, Dual Channel, Hall Effect Speed Sensors - 5/8 and 3/4 Threads

Bi-Directional, Round Body with Connector

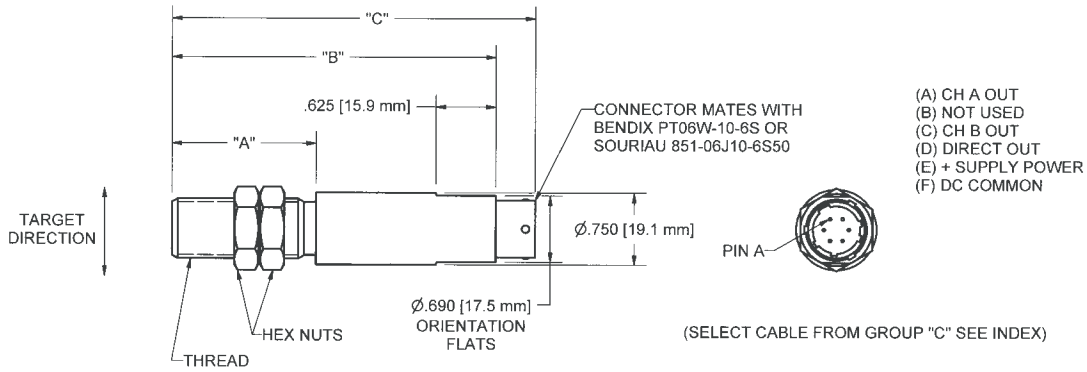

Part Num.	Thread	"A" Dim.	"B" Dim.	"C" Dim. (max.)	Output
BH1512-005	.625-18 UNF-2A	1.500 (38.1)	3.375 (85.7)	3.875 (98.4)	TTL Compatible
BH1522-005					Supply Tracking
BH1512-006		2.750 (69.9)	4.625 (117.5)	5.125 (130.2)	TTL Compatible
BH1522-006					Supply Tracking
BH1612-005	.750-20 UNEF-2A	1.500 (38.1)	3.375 (85.7)	3.875 (98.4)	TTL Compatible
BH1622-005					Supply Tracking
BH1612-006		2.750 (69.9)	4.625 (117.5)	5.125 (130.2)	TTL Compatible
BH1622-006					Supply Tracking

Bi-Directional, Fully Threaded with Cable

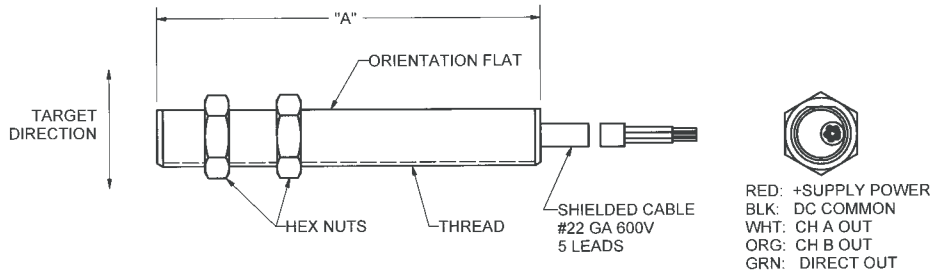

Part Num.	Thread	"A" Dim.	Cable Length	Output
BH1512-009	.625-18 UNF-2A	4.000 (101.6)	10 ft. (3.05m)	TTL Compatible
BH1522-009				Supply Tracking
BH1512-010		6.000 (152.4)		TTL Compatible
BH1522-010				Supply Tracking
BH1612-009	.750-20 UNEF-2A	4.000 (101.6)		TTL Compatible
BH1622-009				Supply Tracking
BH1612-010		6.000 (152.4)		TTL Compatible
BH1622-010				Supply Tracking

Dimensions in inches and (mm).

